

Modeling of Non-Conventional Energy Sources- Solar and Wind Hybrid Model

Ishraque Ahmad¹, Jai Karan Singh²

Abstract — In parallel to developing technology, demand for more energy makes us seek new energy sources. The most important application field of this search is renewable energy resources. Wind and solar energy have been popular ones owing to abundant, ease of availability and convertibility to the electric energy. Matlab based hybrid model of solar and wind is developed. In this model two different power systems i.e. Solar and Wind are combined to supply a single phase load. Initially the elements of solar and wind turbine is studied and the main component of both systems is identified. After that, a hybrid system which consists of the two systems is determined. The data that is used for this simulation is solar irradiance, wind speed and temperature. After the entire element has been determined, the hybrid system is modeled using MATLAB/Simulink. Furthermore, the power output using the data is analysed. With increasing power demand and shortage of fossil fuel, non-conventional energy sources will be more popular in near future

Index Terms— Modeling and simulation of power systems, peak-power tracker (PPT), renewable-energy systems, Hybrid power system(HPS)

1 INTRODUCTION

In India the total installed Capacity of Generation (as on 28-02-2011) was 171926.40 MW. On May 2012, it increased to 202 GW. Various Power Sources i.e. Thermal, Hydro and Nuclear called as Conventional sources accounts for most of the contribution in Generation of Power.[10]

Contribution of various power sources to generation of Electricity is:

Table1.1 contribution of different power sources

Power Plant	Electricity Generated
Thermal	64.75 %
Hydroelectric	21.73 %
Nuclear	2.78 %
Renewable Energy Sources	10.73 %

- *Ishraque Ahmad is currently pursuing masters degree program in electrical power system engineering in RGPV University, Bhopal (M.P.), India, Mob.No.09373124944- E-mail: ishraqezaid@gmail.com*
- *Jai karan Singh is currently pursuing masters degree program in electric power engineering in University, Country, PH-01123456789. E-mail: author_name@mail.com*
(This information is optional; change it according to your need.)

India's Energy demand, more than 50% is met mostly through Thermal power plant dependent on coal reserves. This fossil fuel is fast exhausting and also causing pollution.

Due to the rapid Industrialization and Advancing Technologies, the country's energy demand has grown an average of 3.6% per annum over the past 30 years. The total demand for electricity in India is expected to cross 950,000 MW by 2030.

Loss of power due to transmission and distribution is extremely high; varying between 30 to 45%. India's economic growths is adversely affected by power cuts resulting from shortage of electricity. India faced a power deficit of 73,050 million units between April 2007 and March 2008, according to an audit.

We have to seek alternative sources of Energy; Renewable Energy sources are the most promising fields in the search. The term Green energy can be associated with environment-friendly Generation, transport, storage and control of electrical energy. Solar power, wind power and the natural flow of water are resources that comply with our definition of Green Energy. [10]

Current installed capacity of various power systems as of February 28, 2011, total being 171926.40 MW as follows:-

Thermal power

- 1] Thermal power: 111324.48 MW which is 64.75% of total installed capacity.
- 2] Coal based Thermal Power: 92418.38 MW which is 53.75% of total installed capacity
- 3] Gas Based Thermal Power: 17706.35 MW which is 10.3% of total installed capacity.
- 4] Oil Based Thermal Power: 1,199.75 MW which is 0.9 % of total installed capacity.
- 5] The state of Maharashtra is the largest producer of thermal power in the country.

Hydro power

- 1] The installed capacity was 37367.4 MW
- Nuclear power**
- 1] 20 Nuclear power reactors produce 4,780 MW

Renewable energy

It is still undeveloped .The share of Renewable Energy in the energy sector is less than 1% of India's total energy needs. [10]

Since the natural fossil energy resources are limited on this planet, we have to put our focus on Green power generation like solar and wind power.

Hybrid Power Systems (HPS) are the power systems combining different power systems.HPS being combination of more than one energy source, the system need not have to be dependent on any one system ; making the system more efficient and reliable.

The main objectives of this paper is implementing and develop a software application to analyse and simulate a real hybrid solar-wind system connected to a local grid using Matlab Simulink environment. The hybrid unit contains two complete generating plants, a solar plant and a wind system.The two sources are connected in parallel, the power is connected to a DC to AC inverter and is then supplied from the inverters output to a single phase load.

We propose to design the supervisory control system via model predictive control (MPC) which computes the power references for the wind and solar subsystems at each sampling time while minimizing a suitable cost function. The power references will be sent to two local controllers which drive the wind and solar subsystems to the desired power reference values. MPC is a popular control strategy Hybrid Electric systems combine wind and solar photovoltaic technologies offering several advantages over either single system. Using these predictions, the input/set-point trajectory that minimize a given performance index over a finite-time horizon will be computed solving a suitable optimization problem subject to constraints. In this work, we discuss how we can incorporate practical considerations (for example, how to extend the life time of the equipments by reducing the peak values of inrush or surge currents) into the formulation of the MPC optimization problem by determining an appropriate cost function and constraints.

2. Problem formulation and identification

Nowadays, the use of fossil fuel is growing exponentially. The sources of electricity such as coal, gas and oil has been reduced from year to year. So there is a need to find another source to produce stable electricity generation. Another effect of the lack of other sources is that the price of oil and gas is hiking. Because of these reasons, the use of renewable energy become essential and must be applied soon.

The electricity is one of the most needed energy because people need it in day to day life. There is need of generation of electricity because the resources that are used for electricity generation will be reduced year by year. In conventional way, the electricity is generated using coal, oil gas and etc. Since uel energy sources reduce every year, renewable energy is needed. The electricity generated by using these sources is more efficient and environmental friendly.

Conventional energy sources are depleting .Focus should be shifted on RES as a long term solution. [10]

Achieving major renewable energy production goals requires addressing key fundamental challenges in the operation and reliability of intermittent (variable output) renewable resources like solar- and wind-based energy generation systems. Specifically, unexpected drops in energy production of a solar or wind energy system may require quick start units to cover the shortfall while unexpected increases require the ability to absorb the unscheduled generation. One way to deal with the variable output of wind and solar energy generation systems is through the use of integrated energy generation systems using both wind and photovoltaic energy, which are also tightly integrated with distributed energy storage systems (batteries) and controllable energy loads like, for example, a water production system that operates at controllable time intervals to meet specific demand. With respect to previous results on control of wind and solar systems, most of the efforts have focused on standalone wind or solar systems. Specifically, there is a significant body of literature dealing with control of wind energy generation systems while several contributions have been made to the control of solar-based energy generation systems. However, there are few works that have focused on the control of standalone hybrid wind-solar energy generation systems. A reduced-order nonlinear model was used to design a controller to regulate the wind power generation to complement the power generated by a photovoltaic subsystem and to satisfy a specific power demand. A sliding mode control techniques were used to control the power generated by a photovoltaic array in order to satisfy the total instantaneous power demand in a highly uncertain operating environment. A supervisory control system was developed to satisfy the load power demand and to maintain the state of charge of the battery bank to prevent blackout. In a recent work a cost-effective control technique was proposed for maximum power point tracking from the photovoltaic array and wind turbine under varying climatic conditions without measuring the irradiance of the photovoltaic or the wind speed. However, no attention has been given to the development of supervisory control Systems for standalone hybrid wind-solar energy generation systems that take into account optimal allocation of generation assignment between the two subsystems. [2]

3. PROPOSED METHODOLOGY

3.1 SOLAR POWER PLANT:-

The block diagram of solar power plant as shown in fig3.1

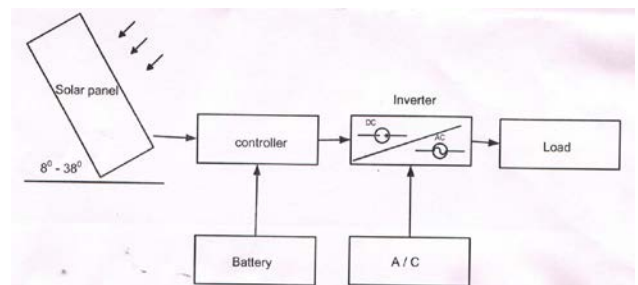

Photovoltaic cells

Photovoltaic panels consist of several modules; modules are composed of cells which are in series. Photovoltaic cells transform luminous energy (solar) into electrical energy. The equivalent circuit of a photovoltaic cell is shown in fig.3.2

It consists of an ideal source producing a current I_{ph} , proportional to incident light, in parallel with a diode D . Shunt resistance R_p models the effect of leak current but in many cases this can be neglected due to its relative large value.[1]

Solar panel : A solar cell (also called photo voltaic cell) is a device that converts the energy of sunlight directly into electricity by the photo voltaic effect .Assemblies of cells are used to make solar modules also known as solar panels.[1]

Photovoltaic cell : - A photovoltaic cell is the basic device that converts solar radiation into electricity. It consists of a very thick n-type crystal covered by a thin n-type layer exposed to the sunlight.Cells are arranged in a frame to form a module .Modules put together form a panel .Panels form an array .Each PV cell is rated for 0.5- 0.7 v and a current of 30 mA/sq.cm.[1]

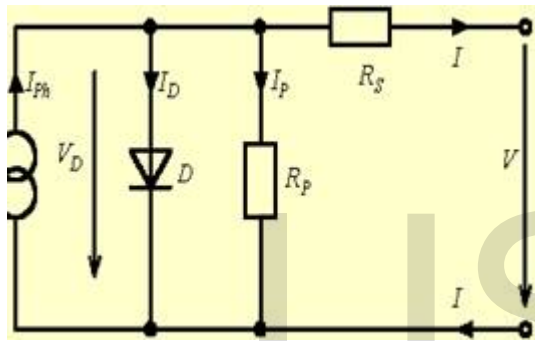

Fig.3.2 PV cell model



fig3.3: solar panel

3.2 WIND POWER:-

Wind Power is very popular nowadays, because of the high power that can be achieved in a efficient way.

The Wind is identified as a key natural energy resource, which contributes to reducing undesirable emissions due to fossil fuel power plant operation. Worldwide installed wind power capacity has reached 120GW at the end of 2008 with a 36% increase in comparison to the previous year.

However, with the increase of wind power penetration, the technical and operational challenges associated with wind energy have also become more apparent. These challenges include, the elimination of power fluctuations, improving power

quality, connection of wind farms to weak grids, prediction of wind power and changes in operating strategies of conventional power plants.

Wind turbines are used to convert the wind power into electric power. Electric generator inside the turbine converts the mechanical power into the electric power. Wind turbine systems are available ranging from 50w to 2-3 MW.

Mechanical output of turbine of wind generator is dependent on the speed of turbine. For small turbines, wind speed is about 3.5m/s. large wind power plants require wind speed of 6m/s. But wind speeds higher than this are available in many locations.

India has the fifth largest installed wind power capacity in the world.

It is estimated that 6000 MW of additional wind power capacity will be installed in India by 2012.Wind power accounts for 6% of India's total installed power capacity and it generates 1.6% of the country's power. [10]

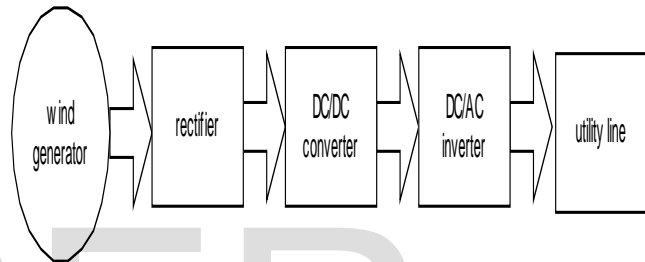

fig3.4 Block Schematic for Wind Power Plant

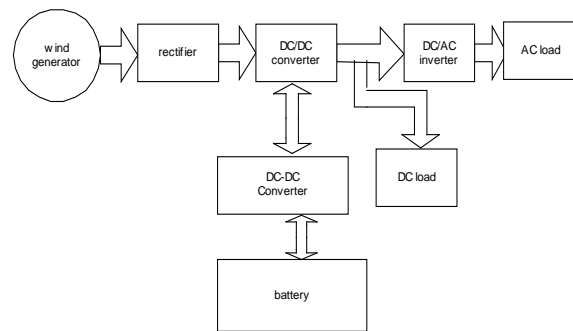

fig 3.5 The grid-connected application

The AC/DC/AC converter is divided into two components: the rotor-side converter (C_{rotor}) and the grid-side converter (C_{grid}). C_{rotor} and C_{grid} are Voltage-sourced converters that use forced-commutated power electronic devices to synthesize an AC voltage from a DC voltage source. A capacitor connected on the DC side acts as the DC voltage source. A coupling inductor L is used to connect C_{grid} to the grid. The three-phase rotor winding is connected to C_{rotor} by slip rings and brushes and the three-phase stator winding is directly connected to the grid. The power captured by the wind turbine is converted into electrical power by the induction generator

and it is transmitted to the grid by the stator and the rotor windings. The control system generates the pitch angle command and the voltage command signals V_r and V_{gc} for C_{rotor} and C_{grid} respectively in order to control the power of the wind turbine, the DC bus voltage and the reactive power or the voltage at the grid terminals. [4]

3.3 HYBRID POWER STATION:-

Hybrid Electric systems combine wind and solar photovoltaic technologies offering several advantages over either single system. Wind speeds are low in summer when the sun shines the brightest and longest. The wind is strong in winter when less sunlight is available. Because the peak operating times for wind and solar systems occur at different times a day and year, hybrid systems are likely to produce power when required.

The hybrid unit contains two complete generating plants, a solar plant and a wind system. The two sources are connected in parallel, and the power is connected to a DC to AC inverter and is then supplied from the inverters output to a single phase load.

The development path of solar wind hybrid systems in India since 1994 an aggregate capacity of 1.07 MW of aerogenerators or hybrid systems was installed under the programme up to December 2010. Almost 57% of the total cumulative installations in the country are followed by Goa, Karnataka, West Bengal, Manipur and Tamil Nadu.

In this hybrid system, there are three subsystems: wind subsystem, solar subsystem, and a lead-acid battery bank which is used to overcome periods of scarce generation. [4]

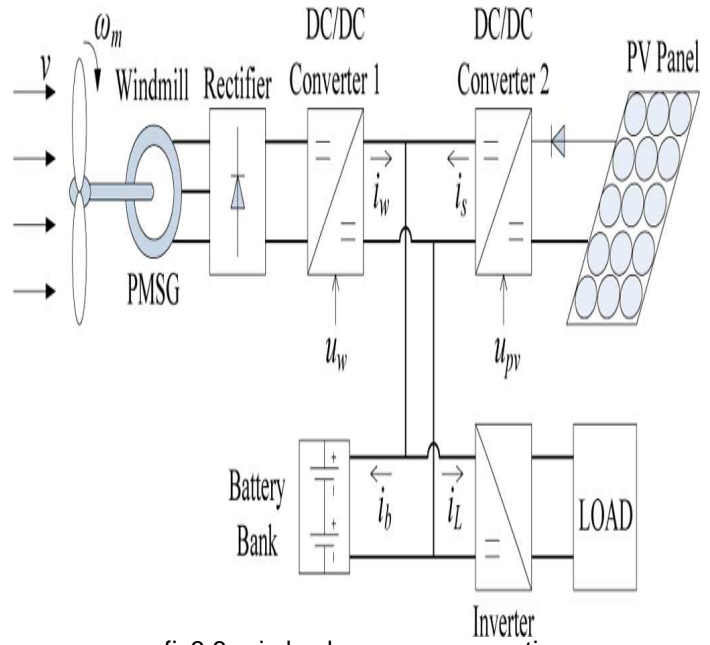

fig3.6. wind-solar energy generation

fig3.7: block schematic of hybrid power plant (wind and solar)

4. Simulation and Experimental Result

4.1 Modelling of the wind energy converter is made considering the assumptions: Frictionless; Constant wind flow; Incompressible flow ($\rho=1.22 \text{ kg/m}^3$); Free wind flow around the wind energy converter. The wind turbines use the energy of the air as the main energy for obtaining electric power.

For calculating electrical power from wind generator, equation of electrical power is given as,

$$\text{Power} = \frac{1}{2} \times \rho \times A \times C_p \times V^3 \times \eta_g \times \eta_b$$

where,

- ρ = Density of air
- V = velocity of wind
- A = Area of cross section of blade movement
- C_p = Power coefficient
- η_g = Wind generator efficiency
- η_b = Bearing Efficiency

Our visit to the meteorological department of Nagpur. For the analysis of hybrid system we collect the data of solar radiation and wind speed from January to March month. The hybrid system which is design in simulink showing the result of January month .as from the result solar power model is feasible for Nagpur city but the wind power model is not feasible, because the wind speed in Nagpur is below 10 km/hr. wind power model will be applied in coastal areas.

The value of average solar radiation for a week of a January

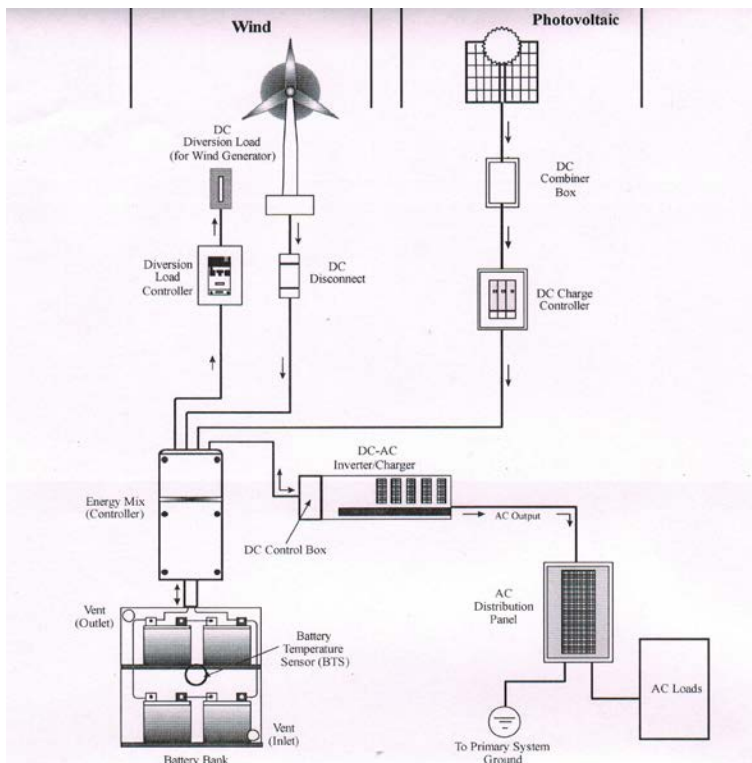

The average wind speed and solar radiation

Average wind speed in January month 2013(km/hr)	Week in January month
3.57	1 week
4.14	2 week
3.57	3 week
4.42	4 week
6.33	5 week

Average solar radiation in January month 2013	Week in January month
4.27	1 week
9.44	2 week
9.72	3 week
7.48	4 week
6.64	5 week

The power incident on a PV module depends not only on the power contained in the sunlight, but also on the angle between the module and the sun. When the absorbing surface and the sunlight are perpendicular to each other, the power density on the surface is equal to that of the sunlight i.e., the power density will always be at its maximum when the PV module is perpendicular to the sun.

The amount of solar radiation incident on a tilted module surface is the component of the incident solar radiation which is perpendicular to the module surface. The figure shows how to calculate the radiation incident on a tilted surface (S_{module}) given either the solar radiation measured on horizontal surface ($S_{horizontal}$) or the solar radiation measured perpendicular to the sun ($S_{incident}$).

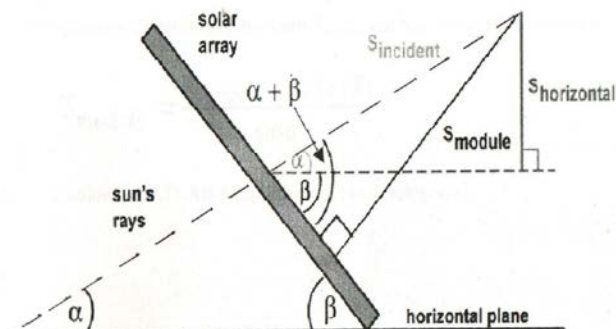

fig.4.1 radiation incident on a tilted surface

Solar Power Expression

The equations relating S_{module} , $S_{horizontal}$ and $S_{incident}$ are :

$$S_{horizontal} = S_{incident} \times \sin \alpha$$

$$S_{module} = S_{incident} \times \sin(\alpha + \beta)$$

Where,

α is the elevation angle :

β is the tilt angle of the module measured from the horizontal surface

The elevation angle is given as $\alpha = 90 - \Phi + \delta$

Where,

Φ is the latitude;

δ is the declination angle

But declination angle is given as

$$\delta = 23.45^\circ \sin \left[\frac{360}{365}(284+d) \right]$$

Where,

d is the day of the year such that $d=1$ on the 1st January

From above equations a relationship between S_{module} and $S_{horizontal}$ can be determined as

$$S_{module} = \frac{S_{horizontal} \sin(\alpha + \beta)}{\sin \alpha}$$

Based on the mathematical equations, a model for a PV module is developed using MATLAB/Simulink. The PV module that has been designed is shown in Figure. The input quantities (solar irradiance, W/m^2 , temperature, $^\circ C$ and voltage, V_m) together with the manufacturer data are used to calculate the module current for PV. V_m is the voltage of the maximum power point and roughly independent of irradiance. The average value of this voltage during the day can be estimated as 80% of the open circuit voltage. The output for PV module is module current (A) and power (W).

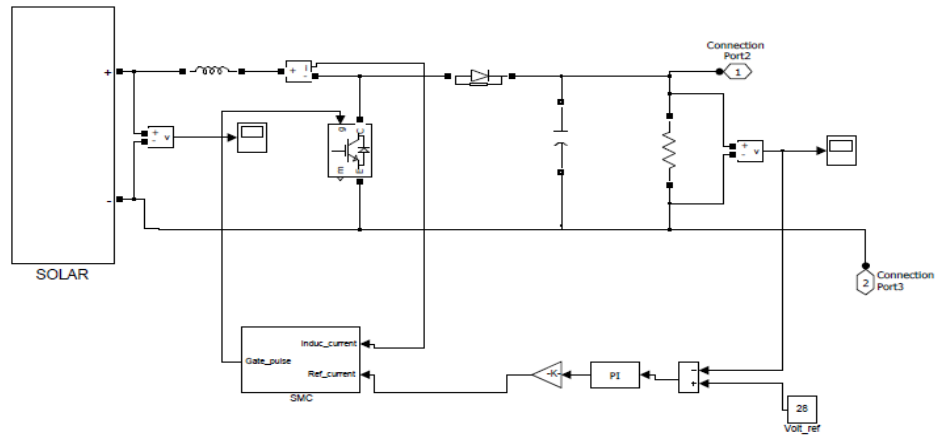

Fig 4.2.Simulation model of solar power system

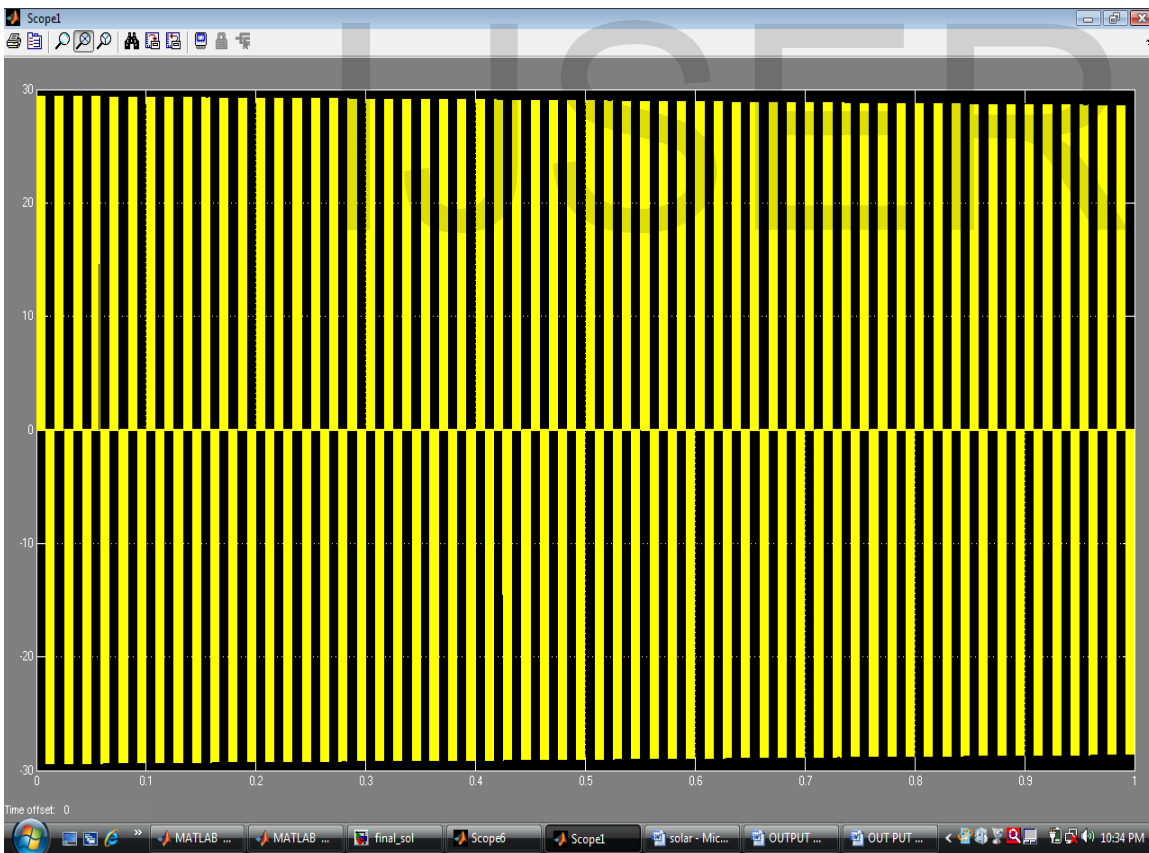

fig.4.3 output of solar power system (voltage vs time)

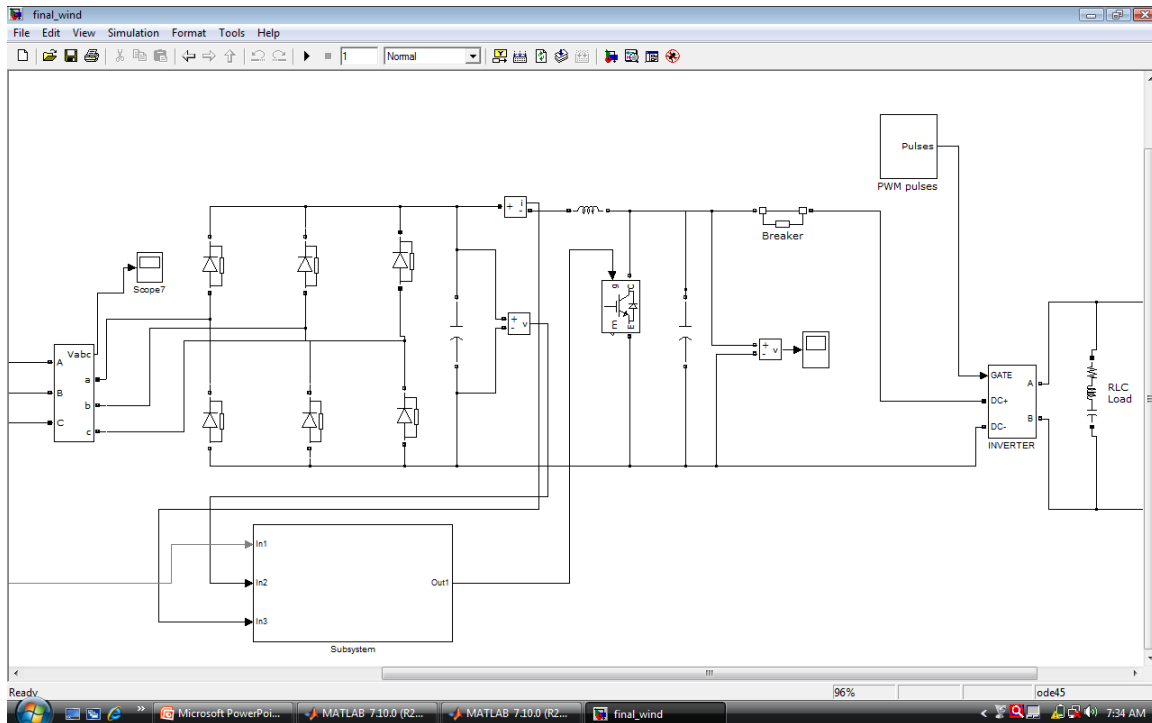

Fig 4.4 simulation model of wind generator

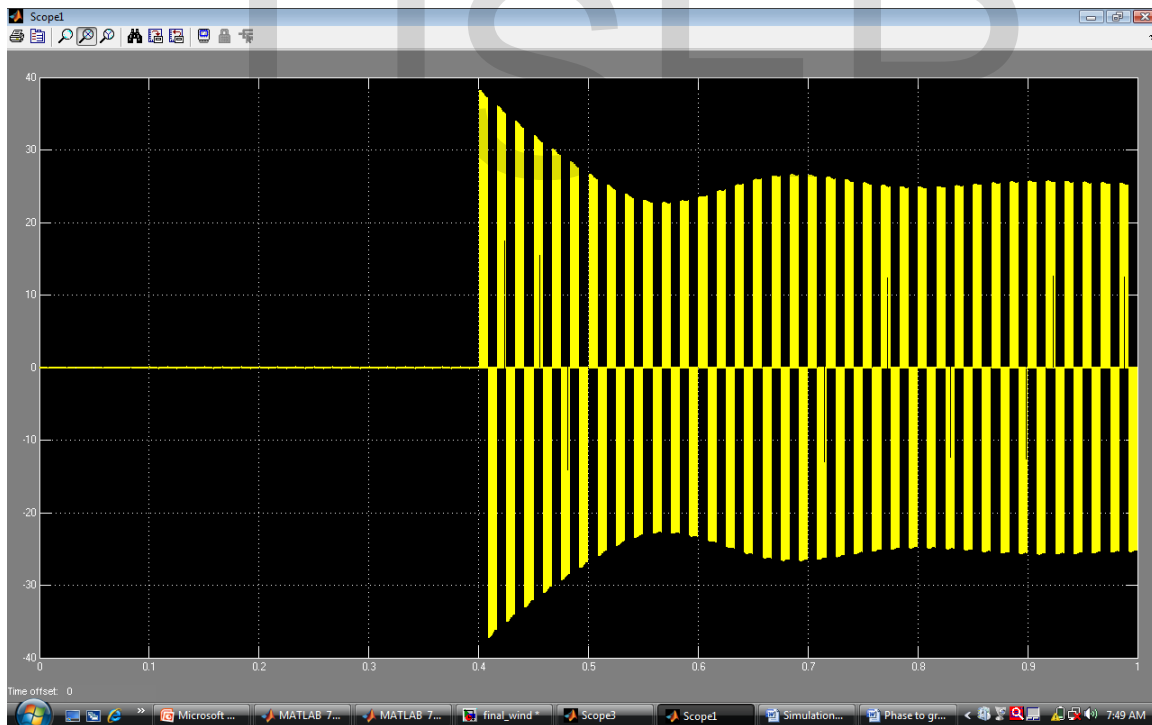

Fig 4.5 output of wind generator (voltage vs time)

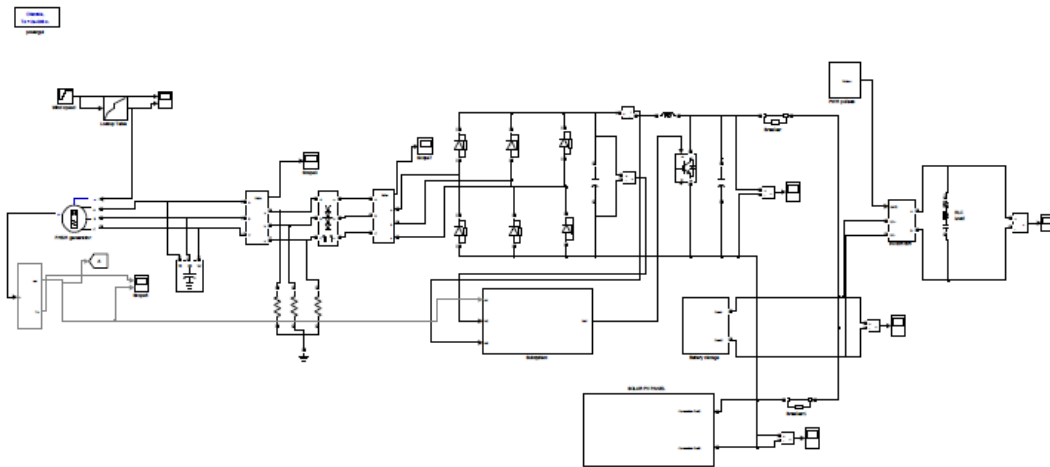

Fig 4.6 simulation model of hybrid power system (solar and wind)

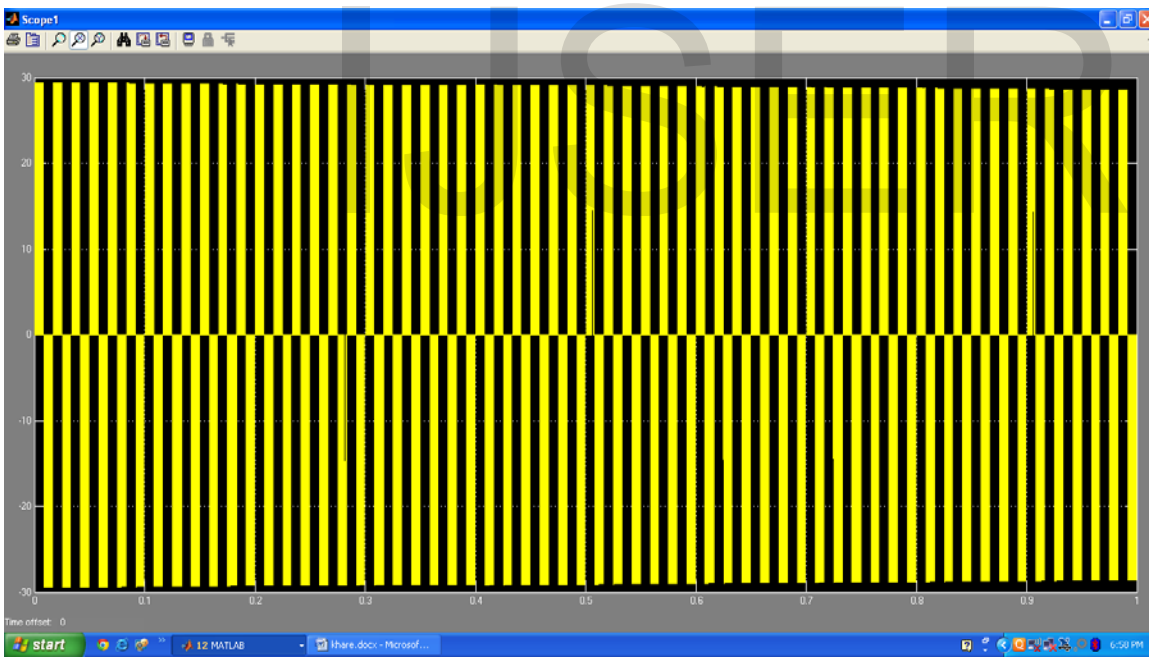

Fig4.7 output of hps (voltage vs time)

CONCLUSION:

This project presents the modeling of a solar-wind hybrid system. Based on presented mathematical models was realized a Matlab/Simulink application useful for analyse and simulate a real hybrid solar-wind system connected to a local grid. Application is built on modular architecture to facilitate easy study of each component module influence.

Blocks like wind model, solar model, energy conversion

and load are implemented and the results of simulation are also presented. With the proposed application many situations can be studied. An important study is the behavior of hybrid system which allows employing renewable and variable in time energy sources while providing a continuous supply. Application represents a useful tool in research activity and also in teachin

REFERENCES

- [1] I.a. adejumobi, s.g. oyagbinrin, f. G. Akinboro & m.b. olajide4 "hybrid solar and wind power: an essential for formation communication technology in frastructure and people in rural communities" inijrras 9 (1) october 2011, pp130 to 138.
- [2] Wei qi, jinfeng liu, xianzhong chen, and panagiotis d. Christofides, "supervisory predictive control of standalone wind/solar energy generation systems"; iee transactions on control systems technology, vol. 19, no. 1, january 2011, pp199 to 206
- [3] Luiz antonio de souza ribeiro, osvaldo ronald saavedra, shigeaki leite de lima, and josé gomes de matos "isolated micro-grids with renewable hybrid generation: the case of lençóis island"; iee transactions on sustainable energy, vol. 2, no. 1, january 2011, pp 1 to 11
- [4] Toshiro hirose and hirofumi matsuo , "standalone hybrid wind-solar power generation system applying dump power control without dump load"; iee transactions on industrial electronics, vol. 59, no. 2, february 2012, pp988 to 997.
- [5] U_ur fesi, raif bayir, mahmut ozer "design and implementation of a domestic solar-wind hybrid energy system." March 10, 2010 from iee xplora.
- [6] Pragya nema1, r.k. nema2, saroj rangnekar1 "pv-solar / wind hybrid energy system for gsm/cdma type mobile telephony base station" in-ternational journal of energy and environment volume 1, issue 2, 2010 pp.359-366.
- [7] Chedid, member iee & h. Akiki saifur rahman, senior member iee "a decision support technique for the design of hybrid solar-wind power system" iee transactions on energy conversion, vol. 13, no. 1, march 199.
- [8] Jan t. Bialasiewicz, senior member, iee, and eduard muljadi, senior member, iee "analysis of renewable-energy systems using rpm-sim simulator" iee transactions on industrial electronics, vol. 53, no. 4, august 2006
- [9] M. Muralikrishna and v. Lakshminarayana "hybrid (solar and wind) energy systems for rural electrification" vol. 3, no. 5, october 2008 issn 1819-608 arpn journal of engineering and sciences
- [10] b. Gupta "generation and economic consideration", katson publication 2nd edition, chapter1, pp1 to 10
- [10] www.mathwork.