

IOT Based Air Pollution Monitoring System

Harsh N. Shah¹, Zishan Khan², Abbas Ali Merchant³, Moin Moghal⁴, Aamir Shaikh⁵, Priti Rane⁶

^{1, 2, 3, 4,5} Student, Diploma in Computer Engineering, BGIT, Mumbai Central, India

⁶ Assistant Professor, BGIT, Mumbai Central, India

Abstract:-

The level of pollution is increasing rapidly due to factors like industries, urbanization, increasing in population, vehicle use which can affect human health. IOT Based Air Pollution Monitoring System is used to monitor the Air Quality over a web server using Internet. It will trigger an alarm when the air quality goes down beyond a certain level, means when there are sufficient amount of harmful gases present in the air like CO₂, smoke, alcohol, benzene, NH₃ and NO_x. It will show the air quality in PPM on the LCD and as well as on webpage so that air pollution can be monitored very easily.

The system uses MQ135 and MQ6 sensor for monitoring Air Quality as it detects most harmful gases and can measure their amount accurately.

KEYWORDS: Air Pollution, MQ135 Sensor, IOT, Arduino Uno.

1. INTRODUCTION :-

Air pollution is the biggest problem of every nation, whether it is developed or developing. Health problems have been growing at faster rate especially in urban areas of developing countries where industrialization and growing number of vehicles leads to release of lot of gaseous pollutants. Harmful effects of pollution include mild allergic reactions such as irritation of the throat, eyes and nose as well as some serious problems like bronchitis, heart diseases, pneumonia, lung and aggravated asthma. According to a survey, due to air pollution 50,000 to 100,000 premature deaths per year occur in the U.S. alone. Whereas in EU number reaches to 300,000 and over 3,000,000 worldwide. IOT Based Air Pollution Monitoring System monitors the Air quality over a web server using Internet and will trigger an alarm when the air quality goes down beyond a certain threshold level, means when there are sufficient amount of harmful gases present in the air like CO₂, smoke, alcohol, benzene, NH₃, LPG and NO_x. It will show the air quality in PPM on the LCD and as well as on webpage so that it can monitor it very easily. LPG sensor is added in this system which is used mostly in houses. The system will show temperature and humidity. The system can be installed anywhere but mostly in industries and houses where gases are

mostly to be found and gives an alert message when the system crosses threshold limit.

2. Literature Review :-

The drawbacks of the conventional monitoring instruments are their large size, heavy weight and extraordinary expensiveness. These lead to sparse deployment of the monitoring stations. In order to be effective, the locations of the monitoring stations need careful placement because the air pollution situation in urban areas is highly related to human activities (e.g. construction activities) and location-dependent (e.g., the traffic choke-points have much worse air quality than average).

IOT Based Air Pollution Monitoring System monitors the Air Quality over a webserver using internet and will trigger an alarm when the air quality goes down beyond a certain level, means when there are amount of harmful gases present in the air like CO₂, smoke, alcohol, benzene, NH₃, NO_x and LPG.

The system will show the air quality in PPM on the LCD and as well as on webpage so that it can be monitored very easily. Temperature and Humidity is detected and monitored in the system.

LPG gas is detected using MQ6 sensor and MQ135 sensor is used for monitoring Air Quality as it detects most harmful gases and can measure their amount accurately. In this IOT project, it can monitor the pollution level from anywhere using your computer or mobile. This system can be installed anywhere and can also trigger some device when pollution goes beyond some level, like we can send alert SMS to the user.

3. Requirements:-

3.1 Hardware Requirement:-

- 1) MQ135 Gas sensor
- 2) Arduino Uno
- 3) Wi-Fi module ESP8266
- 4) 16x2 LCD
- 5) Breadboard
- 6) 10K potentiometer
- 7) 1K ohm resistors
- 8) 220 ohm resistor
- 9) Buzzer
- 10) MQ 6 LPG gas sensor
- 11) Temperature sensor LM35
- 12) Humidity sensor SY-H5220

3.2 Software Requirement:-

- 1) Arduino 1.6.13 Software
- 2) Embedded C Language

4. BLOCK DIAGRAM AND WORKING:-

4.1 Working:-

Proposed Air Pollution Monitoring System is based on the block diagram as shown in Fig.1. The data of air is recognized by MQ135 gas sensor and MQ6 LPG gas sensor. The MQ135 sensor can sense NH₃, NO_x, alcohol, Benzene, smoke, CO₂. So it is dynamic gas sensed for our Air pollution Monitoring system. When it will be connected to Arduino then it will sense all gases, and it will give the Pollution level in PPM

(parts per million). MQ135 gas sensor will give the output in form of voltage levels and we have to convert it into PPM. So for converting the output in PPM, we have used a library for MQ135 gas sensor and MQ6 sensor.

Sensor is giving us value of 90 when there is no gas near it and the air quality safe level is 350 PPM and it should not exceed 1000 PPM. When it will exceed the limit of 1000 PPM, it will cause Headaches, sleepiness and stagnant, stuffy air. If it exceeds beyond 2000 PPM then it will cause increased heart rate and many different diseases. When the value will be less than 1000 PPM, then the LCD and webpage will display “Fresh Air”. When the value will increase from 1000 PPM, then the buzzer will start beeping and the LCD and webpage will display “Poor Air, Open Windows”. And when it will increase 2000, the buzzer will keep beeping and give an alert message on smartphone through GSM. The LCD and webpage will display “Danger! Move to fresh Air”. It will contain temperature and humidity so it will possibly show the current temperature and humidity of the air. For temperature we have used LM35 sensor and for humidity SY-HS-220.

According to the model the 4 sensors works as input data, they transmit data for knowing which gas it is, what is the temperature and humidity. LCD and Buzzer are the output devices. LCD shows the data of the gases in ppm (parts per million) and Buzzer is used when ppm crosses above a threshold limit.

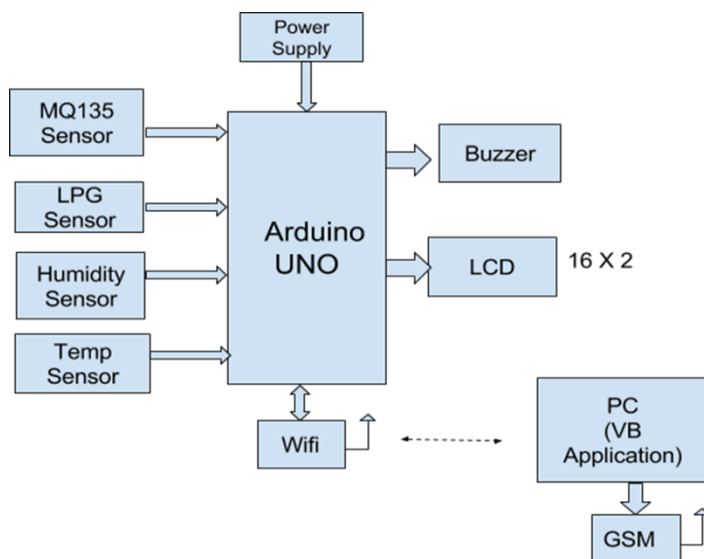

Fig. 1: Block Diagram

5. Components:-

1) Arduino UNO:-

Arduino Uno is a microcontroller board based on the ATmega328P

It has 14 digital input/output pins 6 analog inputs, a 16 MHz quartz crystal, a USB Connection, power jack, an ICSP header and a reset button as shown in Fig. 2



Fig. 2: Arduino UNO

2) MQ135 sensor:-

The MQ135 sensor can sense NH₃, NO_x, alcohol, Benzene, smoke, CO₂ and some other gases.

It gives the output in form of voltage levels.

Fig.3 shows the sensor MQ135.



Fig. 3: MQ135

3) WIFI Module (ESP8266):-

The ESP8266 is a low-cost Wi-Fi chip with full TCP/IP stack and MCU (microcontroller unit) capability.

It runs on 3.3V and gives our system access to Wi-Fi or internet. Fig.4 shows Wi-Fi Module (ESP8266).



Fig. 4: Wifi Module

4) Buzzer:-

A Buzzer or beeper is an audio signaling device.

Whenever the air pollution goes above the threshold level the Buzzer starts beeping indicating Danger. Fig.5 shows Buzzer.



Fig. 5: Buzzer

5) LCD (Liquid Crystal Display):-

This is a basic (16x2) 16 character by 2 line display. Black text on Green background.

It is used to indicate the Air and Humidity in PPM. Fig. 6 shows LCD (16x2).



Fig. 6: LCD

6) GSM Module:-

GSM Module is used to establish communication between a computer and a GSM system.

Global System for Mobile communication (GSM) is an architecture used for mobile communication. Fig. 7 shows GSM Module.



Fig. 7: GSM Module

7) LPG Sensor:-

MQ-6 sensor is a simple-to-use liquefied petroleum gas (LPG) sensor, suitable for sensing LPG (composed of mostly propane and butane) concentrations in the air.

The MQ-6 can detect gas concentrations anywhere from 200 to 10000ppm. Fig.7 shows LPG sensor (MQ6).



Fig. 8: MQ6

8) Temperature Sensor:-

The LM35 is precision integrated-circuit temperature sensor, whose output voltage is linearly proportional to the Celsius (Centigrade) temperature.

It can be used with single power supplies, or with plus and minus supplies. Fig.9 shows LM35 sensor for Temperature.



Fig. 9: LM35 (Temperature)

9) Humidity Sensor:-

The humidity sensor is of capacitive type, comprising on chip signal conditioner.

However, it is mounted on the PCB, which also consists of other stages employed to make sensor rather smarter.

The PCB consists of CMOS timers to pulse the sensor to provide output voltage. Fig.10 shows SY-HS-220 sensor for Humidity.



Fig. 10: SY-HS-220 (Humidity)

5. Applications:-

- 1) Industrial perimeter monitoring
- 2) Indoor air quality monitoring.
- 3) Site selection for reference monitoring stations.
- 4) Making data available to users.

6. Advantages:-

- 1) Easy to Install
- 2) Updates On mobile phone directly
- 3) Accurate Pollution monitoring
- 4) Remote location monitoring

7. Conclusion:-

The system to monitor the air of environment using Arduino microcontroller, IOT Technology is proposed to improve quality of air. With the use of IOT technology enhances the process of monitoring various aspects of environment such as air quality monitoring issue proposed in this paper. Here, using the MQ135 and MQ6 gas sensor gives the sense of different type of dangerous gas and arduino is the heart of this project.

Which control the entire process. Wi-Fi module connects the whole process to internet and LCD is used for the visual Output.

7. References:-

- [1]<https://securedstatic.greenpeace.org/india/Global/india/Airpocalypse--Not-just-Delhi--Air-in-most-Indian-cities-hazardous--Greenpeace-report.pdf>
- [2]<content/uploads/2008/04/5v-regulator-using-7805.JPG>
- [3]<https://store.arduino.cc/arduino-uno-rev3>
- [4]<https://www.arduino.cc/>
- [5]<https://www.aliexpress.com/item/1PCS-LOT-Solution-PH-valuo-Temperature-detector-sensor-module-for-arduino-Free-shipping/32620995019.html?spm=2114.4001>

IJSER