

# INTELLIGENT ALCOHOL DETECTION SYSTEM FOR CAR

Vaishnavi.M , Umadevi.V , Vinothini.M , Bhaskar Rao .Y , Pavithra.S

**Abstract-** The purpose of this project is to develop vehicle accident prevention by method of alcohol detector in an effort to reduce traffic accident cases based on driving under the influence alcohol. This project is developed by integrating the alcohol sensor with the microcontroller 16F877A. The alcohol sensor used in this project is MQ-2 which to detect the alcohol content in human breath. An ignition system which will produce spark plugs is build up as a prototype to act like the ignition starter over the vehicle's engine. The ignition system will operate based on the level of blood alcohol content (BAC) from human breaths detected by alcohol sensor. The main purpose behind this project is "Drunk driving detection". Now a days, many accidents are happening because of the alcohol consumption of the driver or the person who is driving the vehicle. Thus Drunken driving is a major reason of accidents in almost all countries all over the world. Alcohol Detector in Car project is designed for the safety of the people seating inside the car. This project should be fitted / installed inside the vehicle.

**Index Terms**— Alcohol detector, LCD ,MQ-2 ,L293D,PIC 16F877

## 1 INTRODUCTION

This paper presents the progress in using a alcohol Detector, a device that senses a change in the alcoholic gas content of the surrounding air. The sensor will then analyze the amount of alcoholic vapors and offer the user some indication of the amount of alcohol present. This device is more commonly referred to as a breath analyzer; as it analyzes the alcohol content from a person's breath. The device is mostly used by law enforcement to determine whether an individual has been driving under the influence of alcohol. Police breathalyzers measures the Blood Alcohol Content, or BAC, of an individual. The unit designed for this project is a simpler version of the breathalyzer used by

police. It will not accurately determine the BAC level of a person. The microcontroller is interfaced with a MQ-2 alcohol gas sensor, which serves as the analog input signal to the controller. There is a LCD attached to six output pins that will function as a display. Depending on the amount of alcohol present, the MQ-2 sensor will analyze its contents and consequently the sensor output voltage will increase. If output voltage increases enough, input pins on the microcontroller will change from active low state to active high state. According to the output of the microcontroller the motor will be driven with the help of L293D as driver IC

## 2. EXPERIMENTAL SECTION

The construction of this system consists of two parts which

- Vaishnavi.M , Umadevi.V , Vinothini.M are currently pursuing Bachelor degree program in Electronics and Communication engineering in Saveetha School of Engineering , India, PH-09566257527. E-mail: vaishu.maheshwaran@gmail.com
- Bhaskar Rao.Y , Pavithra.S Assistant Professor, Electronics and Communication engineering in Saveetha School of Engineering , India

is hardware development and software development. Hardware development involved the designing the circuit

of the project and printed circuit board (PCB) works. While the software developments are focused on simulating the circuit before test to the real component and also designing coding to be embedded in the hardware.

### 2.1.HARDWARE DEVELOPMENT:

#### 2.1.1 MICRO-CONTROLLER 16F877A :

#### MQ -2 SENSOR:

Sensitive material of MQ-2 gas sensor is SnO<sub>2</sub>, which with lower conductivity in clean air. When the target combustible gas exist, The sensor's conductivity is more

higher along with the gas concentration rising. Please use simple electrocircuit, Convert change of conductivity to correspond output signal of gas concentration. MQ-2 gas sensor has high sensitivity to LPG, Propane and Hydrogen, also could be used to Methane and other combustible steam, it is with low cost and suitable for different application.

### CHARACTER CONFIGURATION

- \* Good sensitivity to Combustible gas in wide range
- \* High sensitivity to LPG, Propane and Hydrogen
- \* Long life and low cost
- \* Simple drive circuit

### APPLICATION

- \* Domestic gas leakage detector
- \* Industrial Combustible gas detector
- \* Portable gas detector

### 2.1.2 BUZZER:

#### FEATURES

- The PS series are high-performance buzzers that employ Uni-morph piezoelectric elements and are designed for easy incorporation into various circuits.
- They feature extremely low power consumption in comparison to electromagnetic units.
- Because these buzzers are designed for external excitation, the same part can serve as both a musical tone oscillator and a buzzer.
- They can be used with automated inserters. Moisture-resistant models are also available.

- The lead wire type(PS1550L40N) with both-sided adhesive tape installed easily is prepared.

### 2.1.3 BLOCK DIAGRAM OF THE SYSTEM

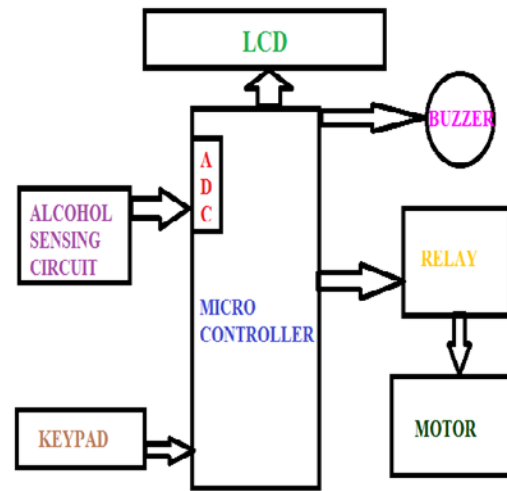

BLOCK DIAGRAM OF THE SYSTEM

### 3. RESULTS AND DISCUSSION :



#### DETECTION OF ALCOHOL CONCENTRATION:

At first, the value of 400 BAC is set in the keypad of the microcontroller. lcd, heat sink ,L293D,mq2,motor, capacitors resistors are all connected together. The alcohol

sensor senses the alcohol level in the air. When the sensed level goes beyond 400 the control will not be sent to the motor and the car will not start. On the other hand if the sensed level is below 400 bac the control will be given to the motor and the car will start. The sensed level depends upon the sensitivity of the alcohol sensor. The alcohol sensor is placed in one of the five ports (RA) in the microcontroller. It senses the alcohol level in the human breath. This value is then sent to the ADC that is connected internally to the microcontroller. This ADC is used to convert the analog values to the digital values and those digital values are in turn sent to the microcontroller. The least alcohol level is initially set in the keypad and the digital value from the ADC is compared with the value that is present in the keypad. The alcohol sensor takes atleast five to ten seconds to sense the value. If the sensed value is less than or equal to the value present in the keypad the control will be sent to the motor and the car will be started. If the sensed value is greater than the keypad value then the car will not start. The sensed value will decrease with time and when the value goes below the set value the car will start. LCD is also connected to the microcontroller which shows all the sensed values. The buzzer is also connected which is used to indicate when the value goes beyond the set value.

## ADVANTAGES

1. To prevent accidents due to drunk and driving.
2. Easy and efficient to test the alcohol content in the body.
3. Quick and accurate results.
4. Helpful for police and provides an automatic safety systems for cars and other vehicles as well.

## APPLICATIONS

1. "Alcohol Detector project" can be used in the various vehicles for detecting whether the driver has consumed alcohol or not.
2. This project can also be used in various companies or organisation to detect alcohol consumption of employees .

## 4. CONCLUSION

In this study, we have empirically demonstrated that Starting with a requirement to develop a non invasive technology that will quickly and accurately measure a driver's BAC, the project team has established a Program Plan, developed Performance Specifications, solicited industry interest, and begun the process of identifying technological approaches that show promise. The goal at the end of the 5-year program is the practical demonstration of an alcohol detection subsystem which is suitable for subsequent installation in a vehicle. The adoption of non-regulatory, voluntary approaches to the implementation of advanced vehicle technology makes it critical that policy and public acceptance issues be addressed concurrent with the technology development. This is particularly important when it comes to the widespread implementation of technologies to prevent alcohol-impaired drivers from getting behind the wheel. The majority of the driving public in the United States either does not drink, or does not drink and drive. It is therefore necessary that advanced technologies to assess BACs must be seamless with the operation of the vehicle and not impede the sober driver. The general public fully understands the dangers of drinking and driving. In a survey on drinking and driving attitudes and behavior (NHTSA, 2003), ninety-seven percent of respondents indicated that drinking and driving is a threat to their personal safety. With the growing public perception that vehicle safety is an important factor in the vehicle purchase decision, advances in safety technology are gaining public acceptance more readily than in the past. Communicating with the public regarding the DADSS program, the potential technologies that are being developed, and the way in which these might be implemented will be an important component of this effort.

## 5. REFERENCES

- 1.Chou, S.P., Grant, B.F., Dawson, D.A., Stinson, F.S., Saha, T., Pickering, R.P. 2006. Twelve month prevalence and changes in driving after drinking. United States, 1991-1992 and 2001-2002. Alcohol Research and Health, 29, 143-151.
- 2.Elder, R.W., Shults, R.A., Sleet, D.A., Nichols, J.L., Zaza, S., Thompson, R.S. 2002.Effectiveness of sobriety checkpoints for reducing alcohol-involved crashes. Traffic Injury Prevention, 3, 266-74.
- 3.Farmer C. M. 2005. Relationships of Frontal Offset Crash Test Results to Real-World Driver Fatality Rates. Traffic Injury Prevention, 6, 31-37.

4.Ferguson, S.A. 1999. Consumer demand. North Vancouver, British Columbia, Canada: Insurance Corporation of British Columbia (ICBC).Recovery 10:11-13.

5.Ferguson, S.A., Schneider, L.W. 2008. History and performance of frontal airbags with changes in frontal crash test requirements in the United States. Traffic Injury Prevention, 9, 421-31.

6.Insurance Institute for Highway Safety. 2008. Q&As. Alcohol:General. Arlington, VA.

7.Kahane, C. 1994. Correlation of NCAP Performance with Fatality Risk in Actual Head- On Collisions. DOT HS 808 061. Washington DC: National Highway Traffic Safety Administration, U.S. Department of Transportation

IJSER