

Harvesting Biomechanical Energy Using Pedal Power and Solar Power (Pedaller)

Sai Neeraj Pandari

Abstract— The current needs of the society can be answered by the engineer's for the benefit of the society are alternative energy production, energy conservation, safety, security and helping aids. A "lack of exercise is worse for health than being obese", *The Daily Telegraph* has reported. To address this problem, equipment called pedaller is designed. It uses the biomechanical energy produced by a human, and occupies just a foot space. It is specially designed for people who work for 8-10 hours on their desks. They can exercise for a couple of hours using the pedaller which could be used to power an appliance such as their mobile phone, table lamp or even a laptop. The alternative energy sources employed were pedal power and solar power. Pedal power is the transfer of energy from a human physical source (Bio energy) and Solar power is the conversion of sunlight (natural) into electricity.

Index Terms— *Alternate Energy, Bio-mechanical energy, Fitness, Pedal Power, Solar Energy*

1 INTRODUCTION

THE pedal power exerciser is a multipurpose portable device used for both exercising and generating electricity. Electricity is generated by the motion of an inclined pedal pushing down with each stride as muscles continuously accelerate and decelerate the body, using a series of timing belt drives tied up to small generator. The generated electricity is regulated and charges the buffer battery to 6Vdc with the help of microcontroller based charge control circuit, the charged battery output is regulated and fed into an universal USB connector. From the USB Power port output when a multi charger is plugged, it can charge all types of mobile phones and laptop can be charged; and can switch on a night lamp. A microcontroller along with LCD and keyboard display number of calories burnt by exercising. By using solar power the electricity is converted directly from sunlight through solar panel which is regulated and can be used to charge the buffer battery to 6V dc.

The main reason for biomechanical energy harvesting is that energy production from physical movements is an alternative to conventional energy sources. Arm swing, shoe power, back pack power are most widely used bio mechanical harvesters other than a knee brace [1].

Pedal power

Pedal power is the transfer of energy from a human source through the use of a foot pedal and crank system. Bicycles mainly employ this technique to transfer power. In some developing countries are using pedal powered tools. Although this is a relatively slow method, it is clean energy.

Pedal technology is nearly perfect with 97% efficiency. Using your own power helps you understand the amount of energy you use, reduce your ecological footprint and help you burn some calories. There is nearly one bicycle in every home. We can use pedal power to charge phones, process food, and pump water.

2 ENERGY CALCULATIONS

Most exercisers will display your calorie burn. This may leave you wondering where the number comes from. These estimates aren't plucked out of thin air, but they aren't without their problems. The most equivalent method for calculating energy (number of calories burnt) is called **metabolic equivalent method**

ACTIVITY	MET (METABOLIC EQUIVALENT) VALUE
RESTING	1.0
CYCLING	8.0

Table 1 MET table

Metabolic equivalent method:-

According to physicist and athlete Alex Hutchinson, pedal exerciser calculates your calorie burn in the same way as the Compendium of Physical Activity - a database of physical activities. Hutchinson explains that each activity has a value assigned to it that you can use to estimate the number of calories that you burn per kilogram of body mass. For instance, running, cycling and walking at different speeds have different values because they burn calories at different rates.

The value assigned to different physical activities is known as the metabolic equivalent task (MET) value. Resting has a MET value of 1.0. Running at a speed of 5.2 mph has a MET value of 9.0, which means you use nine times as much energy as you do while at rest. Running at a speed of 4 mph, on the other hand, has a MET value of 6.0, meaning that it uses just six times the energy of resting.

The formula used to find your calorie burn based on MET value is the MET value multiplied by your weight in kilograms and the time of the activity in hours

$$\text{Energy Burnt (calories)} = \text{Weight of body (in pounds)} * \text{MET} * \text{Duration of Exercise (in hours)}$$

Calorie formulas are good in general, but they may not be accurate for all individuals. According to Hutchinson, these formulas are based on data for average individuals. If you have more body fat than the average person you will have an inaccurately high calorie burn estimate because fat burns less calories than muscle. Conversely, if you are more muscular than average the calorie burn estimate will be lower than it should be.

3 COMPONENTS

3.1 Dynamo with Gear Box

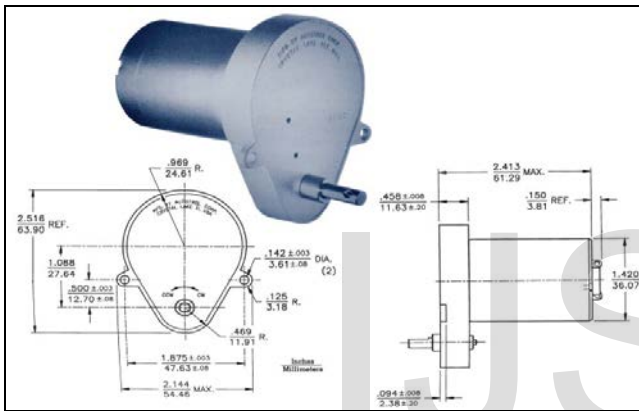

Fig -1: DC generator

Dynamo is used to convert mechanical energy to electrical energy and produces alternating current. This can be used to power devices, which work on ac directly or can be converted to a direct current and used for devices working on dc. The power generated from a dynamo by pedaling is sufficient to power low power devices like electronic gadgets like mobile phones, table lights and iPods. [2]

3.2 Timing Belts

Timing belts are one of the most efficient synchronous drives. This drive employs meshing between tooth on the gears and the tooth on the timing belt. Hence, they do not slip and there is no relative motion between the two elements in mesh. This enables us to maintain a constant speed ratio

As there is no relative motion, these drives are capable of transmitting large torques and can also withstand large accelerations.[3]



Fig -2: Timing Belt

3.3 Solar Panel

Solar panels are devices that convert light into electricity. They are referred to as *photovoltaics* which means, basically, "light-electricity." A solar panel is a collection of solar cells spread over a large area, that work together to provide enough power to be useful. The more light that hits a cell, the more electricity it produces. In this project solar energy is the second alternative energy source. If the person is not pedaling they can place the panel outside in the sun and the battery will get charged. [4].



Fig -3: Poly crystalline solar panel

3.4 Microcontroller (ATmega16)

The ATmega16 is a low-power CMOS 8-bit microcontroller based on the AVR enhanced RISC architecture. By executing powerful instructions in a single clock cycle, the ATmega16 achieves throughputs approaching 1 MIPS per MHz allowing the system designer to optimize power consumption versus processing speed. [5]

ATmega16 is used to calculate the number of calories burnt and also provide the LCD keyboard interface.

3.5 Relay

A relay is an electrically operated switch which is normally closed. It uses an electromagnet to mechanically operate the switch. The dynamo is connected to the battery through the relay. When the battery is fully charged it will be opened to

avoid overcharging of the battery.

3.6 Low Dropout Voltage Regulator (LM2940)

The LM2940-N and LM2940C positive voltage regulators feature the ability to source 1 A of output current with a dropout voltage of typically 0.5 V and a maximum of 1 V over the entire temperature range. It is used to provide a constant 5V power supply to the USB. The input is taken from the battery and the regulated output is given to the USB for charging.[6]

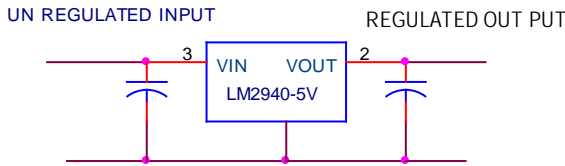

Fig -4: LM2940 Schematic

3.7 Real Time Clock (RTC)

An RTC is a computer clock that keeps track of current time- available in 8-Pin Plastic DIP- this term generally refers to personal computers, servers etc. It is found in almost all electronic devices which require keeping an accurate track of time. It runs on special battery (Lithium) that is not connected to normal power supply. The RTC provides time even if the microcontroller is off. Back up battery of the RTC powers it and keeps it running. When ever microcontroller is on, RTC sends current time data through Pins SDA and SCL to the microcontroller.

3.8 LCD (Liquid Crystal Display)

The LCD panels are transmissive and can not emit light on their own and therefore require backlights to generate colors on the LCD screen. Backlight structure is different in various applications. Edge type backlights are used for notebooks and monitors, whereas, direct types are used for LCD TVs. In this project LCD is used to display the time, dynamo/solar panel voltage and number of calories burnt.[7].

3.8.1 LCD interfacing to microcontroller

Sending commands and data to LCDs with a time delay:

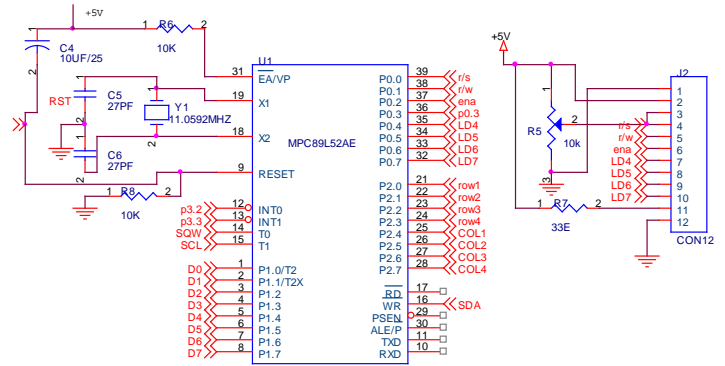

Figure -5: LCD interfacing to microcontroller

To send any command to the LCD, make pin RS=0. For data, make RS=1. Then place a high to low pulse on the E pin to enable the internal latch of the LCD.

3.9 VRLA Battery

A VRLA battery (valve-regulated lead-acid battery), more commonly known as a sealed battery which is a maintenance free and rechargeable battery. Due to their construction, they can be mounted in any orientation, and do not require constant maintenance. The battery is connected to the dynamo and the solar panel via a bridge rectifier. This charges the battery. The battery is then connected to the USB(female) via a low dropout voltage regulator.[8].



Fig -6: VRLA battery

3.10 Bridge Rectifier (W04 M)

A diode bridge or bridge rectifier (full wave rectifier) is an arrangement of four diodes connected in a bridge circuit. The bridge rectifier provides full wave rectification from a two wire pulsating DC from generator, in case the pedal is moved in anti clock or clock wise direction, the bridge rectifier provides the same polarity of output voltage for any polarity of the input voltage. The main purpose of the bridge rectifier is to convert the pulsating DC voltage generated from the dynamo to a DC voltage. [9]

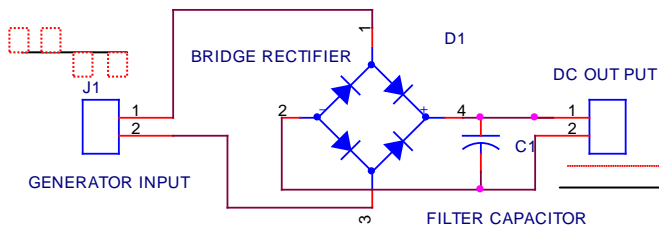

Figure -7: Bridge rectifier

4. Working

Solar panels work on the principle of photovoltaic effect which internally consists of an array of solar cells. Each solar cell is made up of silicon semiconductor. So when sunlight of sufficient energy is made to fall on the solar cell, then electrons jump from valence band to conduction band and create a hole in the valence band. Since the lifetime of electron in conduction band is so less, they immediately try to come back to their original state (valence band) leaving some energy known as photonic energy. In order to efficiently use this liberated energy, we try to create positive and negative charges in between two bands by the principle of doping. So electrons present in conduction band get attracted towards positive charge side and holes get attracted towards negative charge side, thereby creating a flow of charge carriers across the solar panel in a closed loop. This results in generation of current or voltage of approximately 8V DC and this is given to charge the battery with series diode and through a relay, which cut-off charging when the battery reaches around 7 V DC. Initially the relay will be OFF and with normally closed contacts the power from the solar panel and the generator is given to battery for charging, once the battery gets fully charged, then the relay switches ON, the normally closed contact becomes Open and stops charging. There are by pass diodes from both solar panel and generator, the power from these is used directly when not charging the battery. The solar voltage and battery voltage is displayed on the LCD.

The other alternative conventional energy source is pedal power. Pedal power is the transfer of energy from human source using foot pedal and crank system. A small generator is connected to pedals using timing belt with a ratio 1:3. And the output is connected to integral gear box with ratio 1: 15 mounted along with generator. For single revolution pedaling the generator to rotate 48 times and the generator rotates between 200 to 300 RPM based on the pedaling speed. The PMDC generator (dynamo) converts mechanical energy into electrical energy based on the principle of Faraday's law of electromagnetic induction.

Thus the EMF or voltage between 9 to 9.5 Volts is generated by the dynamo and is supplied to battery through the bridge rectifier and normally closed contacts of the relay and blocking diode. The charged battery can power mobile phones and switch ON the lamp.

According to the logic written in the microcontroller, the voltage generated by the dynamo is multiplied with a float value which in turn gives the number of calories burnt. Hence the

LCD displays the number of calories burnt and dynamo voltage.

An RTC is a Real time clock (form of IC) that keeps track of current time. It runs on special battery that is not connected to the normal power supply. The RTC provides time even if the microcontroller is OFF via a Back up battery. Suppose the microcontroller is ON, RTC sends data through SDA (serial data), SCL (serial clock) to microcontroller. In this project, RTC is used to display time and date.



Fig -8: Side View of Final Product

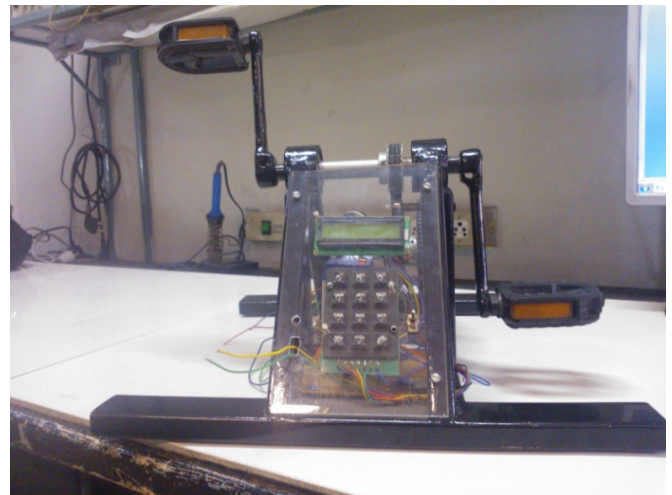

Fig -9: Front View of Final Product

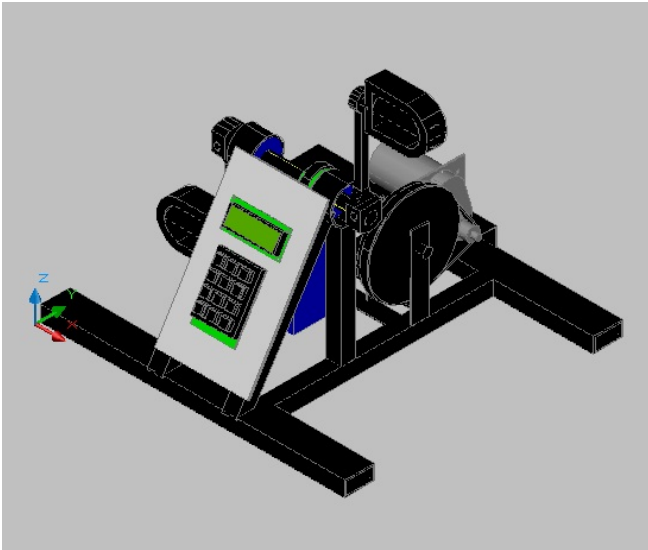

Fig -10: Prototype Design in AutoCAD

5. Softwares Used

AutoCAD for designing the prototype

Code vision AVR for the programming of the microcontroller.
Intelligent Schematic Input System (Icisd) to simulate the project before developing the actual working model.

6. CONCLUSIONS

This project can be further extended to run different household appliances like television, fans, radios and many more. Particularly this revolution can be seen very soon in gyms, so called electricity free gyms, where people exercise to make themselves fit and simultaneously lots of power is generated. The work can still be extended by employing a GSM module to have a weekly report of how many calories are burnt and what diet is to be followed directly to the users mobile phone.

7. ACKNOWLEDGEMENTS

I would like to thank Mr.P. Chandra Shekar, Technical Director, Technique Design Group, for his valuable inputs throughout the project.

REFERENCES

- [1] O.M. Toledo, D. Oliveira Filho and A.S.A.C. Diniz, "Distributed photovoltaic generation and energy storagesystems: A review", Renewable and Sustainable EnergyReviews, Vol. 14, No. 1, pp. 506-511, 2010.
- [2] Rajesh Kannan Megalingam, Pranav Sreedharan Veliyara, Raghavendra Murali Prabhu, Rocky Katoch(2012). Pedal Power Generation. International Journal of Applied Engineering Research Vol.7 No.11 .

- [3] Gurumurthy Veerapathiran, Prabu Dhanapal, Ranjithkumar Koumaravel , Padmanaban Narayanamoorthy, Vignesh Ravi , Chandran(2015). Power Transmission Through Timing Belt In Two Wheeler Motors. Int. Journal of Engineering Research and Applications Vol. 5, Issue 3, (Part -5) March 2015, pp.20-25.
- [4] www.qrg.northwestern.edu/projects/vss/docs/power/1-what-are-solar-panels.html
- [5] www.atmel.com/images/doc2466.pdf
- [6] <http://www.ti.com/lit/ds/symlink/lm2940c.pdf>
- [7] Ankita Tyagi , Dr. S. Chatterjee(2013). Liquid Crystal Display: Environment & Technology. International Journal of Environmental Engineering Science and Technology Research Vol. 1, No. 7, July 2013, PP: 110-123
- [8] http://research.omicsgroup.org/index.php/VRLA_battery
- [9] www.idconline.com/technical_references/pdfs/electronic_engineering/Rectifiers_and_Diode_Bridges.pdf

Sai Neeraj Pandari is currently pursuing Bachelors degree in Mechatronics (Mechanical) engineering in Mahatma Gandhi Institute of Technology, India, PH-919948074407. E-mail: neeraj.54@gmail.com