

# Green House Environment Monitoring and Control System

Anuradha A. Pandit<sup>1</sup> and Avinash V. Mancharkar<sup>2</sup>

<sup>1</sup>Department of Physics, Ahmednagar College, Ahmednagar- 414001, INDIA.

<sup>2</sup>Department of Physics, New Arts, Commerce and Science College, Parner- 414302, INDIA

**Abstract:** Greenhouse Environment, used to grow plants under controlled climatic conditions for efficient production, forms an important part of the agriculture and horticulture sector. To create an optimal environment the main parameters such as temperature, humidity, light intensity, ground water, etc. needs to be controlled. The main objective of this project work is to design an automated greenhouse which is purely sensor based system. The system inputs from various sensors and displays output. The developed system is simple, cost efficient and easily installable. The results show that the system could be more efficient in man power saving and raising the economic value of products.

**Keywords:** Greenhouse Environment, Sensors, Control and measurement.

**\*Corresponding Author: Dr. A. V. Mancharkar**

**E-mail address:** [mancharkar\\_av@rediffmail.com](mailto:mancharkar_av@rediffmail.com)

----- ◆ -----

## 1) INTRODUCTION:

In recent years improvements in sensor manufacturing technologies have occurred driven by post-process high-speed, low-power and low-cost microelectronic hybrid circuits [1-3]. The requirement for commercial competitiveness is sequential enhancement of quality and product reliability. Furthermore, it is important to know the degree of efficiency of each sensor related to its calibration circumstances and sensing mechanism [4].

We live in the world where every thing can be controlled and operated automatically, but there are still few sectors in our country where automation has not been adopted or not being put to a full-fledged use, perhaps because of several reason one such reason is cost and one such field is 'agriculture'. Agriculture has been one of the primary occupations of man since early civilization and even today manual interventions in farming are inevitable. Greenhouse form an important part of the agriculture and horticulture sectors in our country as they can be used to grow plants under controlled climatic conditions for optimal growth[5]. Greenhouse technology is the technique of providing favorable environmental conditions for plants [6]. It replaces the direct supervision. Now a day, due to urbanization and lack of land availability there is a great need to construct the greenhouse, which will be revered mainly for growing crops[7]. Greenhouse monitoring and controlling projects is used to measure the various parameters like temperature, humidity, light, water content, ph level, moisture, etc. and to display them on LED. Continuous monitoring of these environmental factors gives relevant information pertaining to the individual effects of the various factors towards obtaining effects of the various factorstowards obtaining maximum crop production. Unlike open farming where natures control takes the upper hand, green house prevents a closed environment that can be strictly controlled by humans in order to provide optimal conditions for the growth of plants [8].

The effectiveness in greenhouse crop production depends significantly on the modification of optimal growth conditions to achieve high yield at lower costs, good quality and low environmental load. To achieve these goals several parameters must be optimally controlled as per certain criteria through heating and ventilation, etc [9][10]. Over the years the greenhouse systems became more reliable but with increased complexity. Earlier

automated control systems considering thermostats and timers provided major advances in efficiency and product quality making growers lives simpler.

However, many of these control devices and methods cannot deliver the level of automation and efficiency needed in today's dynamic and competitive environment. Several models have been developed to represent greenhouse environments over the years varying in complexity and details. As operating cost increased and greenhouse systems became increasingly complex, the demands for increased control capability grew. The computer revolution of early 80s created the opportunity to meet the needs for improved control. In the last decade, there has been tremendous rise in the use of computers for green houses. In order to design successful control system it is important to realize that these parameters are interdependent [11][12]. This project presents the systems that collects and automatically controls condition of greenhouse environment and crops by using different sensors. The existing control system monitors temperature, humidity, light intensity, soil moisture. To make up for this week point, this project proposes and collects the information regarding these parameters so that the change of condition of crops depending on internal environment factors of greenhouse can be estimated[13].

## II)SYSTEM DESIGN AND WORKING:

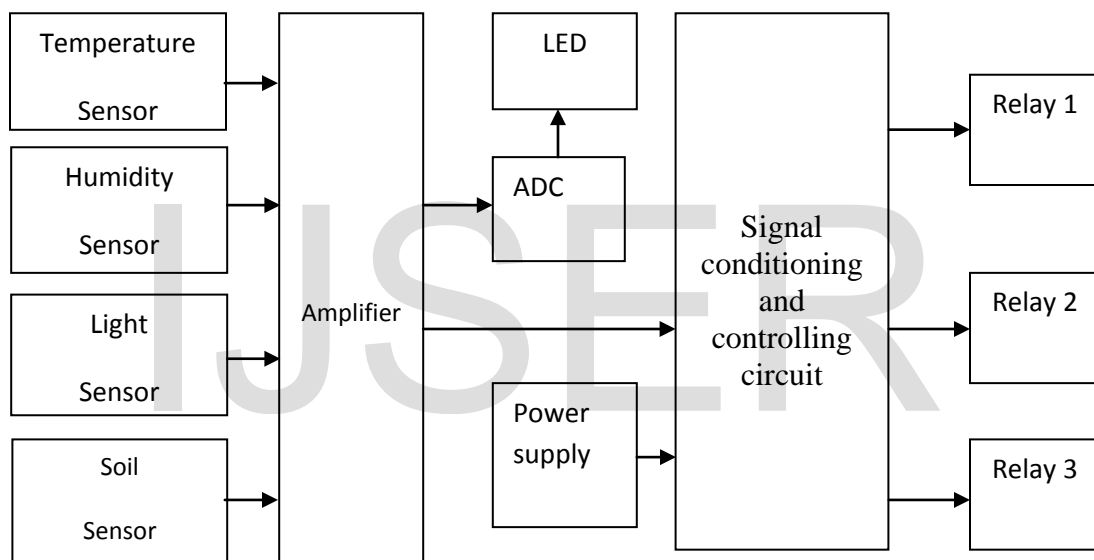

**Fig 1: BLOCK DIAGRAM OF DESIGNED SYSTEM**

The system consists of four subsystems in it and they are:

- I. Temperature monitoring and control system
- II. Light intensity monitoring and control system
- III. Humidity level monitor and control system
- IV. Soil moisture monitoring and control system

The system's temperature monitor and control system works according to the temperature value set by the user. First it gets the value from the user and maintains the temperature on the LED screen for user reference. The temperature of the greenhouse is reduced by the fan that is placed inside the greenhouse. The temperature of greenhouse is increased by using heater which is placed at the floor of the greenhouse to ensure that the whole greenhouse is warmed equally.

The light control system controls the light falling on the greenhouse. When there is not enough light the LDR detects this, and the light bulbs are switched ON. When there is lighter the light bulbs are turned OFF. But at

night the system will automatically get turned ON and this has harmful effects on the plants therefore a switch is placed to OFF the lights at times when we feel the lights are unnecessary.

The humidity level monitoring system monitors and it maintains around a predefined value. When the system detects the drop in humidity level the pipelines installed inside the greenhouse allows water to floor. The pipes contain small hoses and hence allow water to reach the soil quickly. When the humidity level reaches the correct value the system OFFS the motor and flow of water stops.

One LDR is fixed inside the system since light is falling onto the greenhouse evenly. If the light intensity is high the bulbs are switched off if they are once switched ON when the light intensity is low to save power .A switch is place to cut OFF the power supply to the bulbs manually this is because having lights ON at night will make plants weak and consumes more power[14].

### III) HARDWARE DESCRIPTION:

#### SENSORS:

The word ‘sensor’ is derived from the word meaning ‘to perceive’ and ‘transducer’ means ‘to lead across’. A dictionary definition of ‘sensor’ is a device that detects a change in a physical stimulus and turns it into a signal which can be measured or recorded [15] .This project we are using four types of sensor.

- ❖ Temperature sensor
- ❖ Humidity sensor
- ❖ Light sensor
- ❖ Soil moisture sensor

#### A) TEMPERATURE SENSOR:

A number of definitions of temperature have been proposed. In a layman’s language one could define this as the degree of hotness or coldness of a body or an environment measured on a definite scale. Another simplified definition of temperature is based on its equivalence to a driving force or potential that caused the flow of energy as heat. Thus, we can define temperature as a condition of a body by virtue of which heat is transferred to or from other bodies. It may be noted that there is a marked difference between the quantities temperature and heat. Temperature may be defined as ‘degree’ of heat whereas heat is taken to mean as ‘quality’ of heat [16]. Here we use J type temperature sensor. Base metal thermocouples are known as Types E, J, K, T and N and comprise the most commonly used category of Thermocouple. The conductor materials in base metal thermocouples are made of common and inexpensive metals such as Nickel, Copper and Iron.

The Type J thermocouple has an **Iron** positive leg and a **Constantan** negative leg. Type J thermocouples can be used in vacuum, oxidizing, reducing and inert atmospheres. Due to the oxidation (rusting) problems associated with the iron leg, care must be used when using this thermocouple type in oxidizing environments above 1000°F. The temperature range for Type J is 32 to 1400°F and it has a wire color code of white .and red [17].

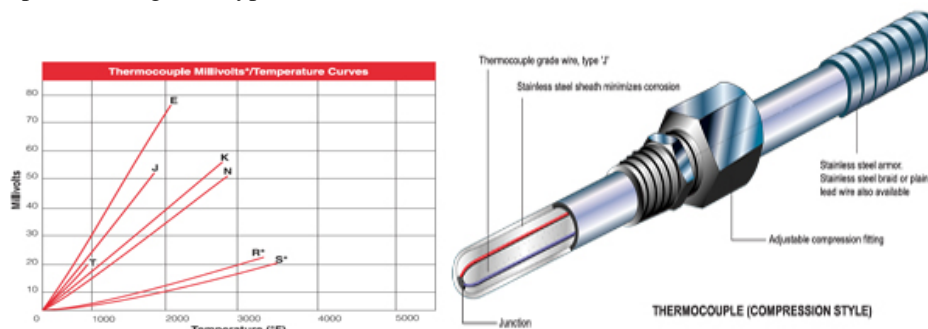

FIG 2: J TYPE THERMOCOUPLE

#### B) HUMIDITY SENSOR:

It is known that humidity plays a significant role in every part of the Earth in biology and automated industrial processes. To have a desirable surrounding atmosphere, it is essential to monitor, detect and control the ambient humidity under different conditions ranging from low temperature to high or in mixtures with other gases by precise and provident sensors [18-19].

Humidity sensing studies have progressed rapidly and humidity sensors—regardless of fabrication technique—have been widely employed in industrial and household applications as instrumentation equipment or for human comfort issues. Due to the different operating conditions of moisture sensors in different areas of application ranging from indoor to open air uses, various types of humidity sensing instruments have been developed based on different work principles and diverse hygroscopic sensing materials [20–21]. Amongst the various humidity evaluation terms and units, absolute humidity and relative humidity are the most prevalent. Based on the units of measurement, humidity sensors are subsumed in two main classes: —Relative Humidity (RH) || and —Absolute Humidity|| sensors (hygrometers). In the majority of humidity measurement applications relative humidity measurements are more preferable than absolute humidity ones. RH% is most commonly used because is generally simpler and thus cheaper and is extensively applied in applications involving indoor air quality and human comfort issues [22].

To measure humidity, amount of water molecules dissolved in the air of playhouses environments, a smart humidity sensor module SY-HS-220 is opted for the system under design. The photograph of humidity sensor SY-HS-220 is shown in the figure 3. On close inspection of figure 3, it is found that, the board consists of humidity sensor along with signal conditioning stages[23].

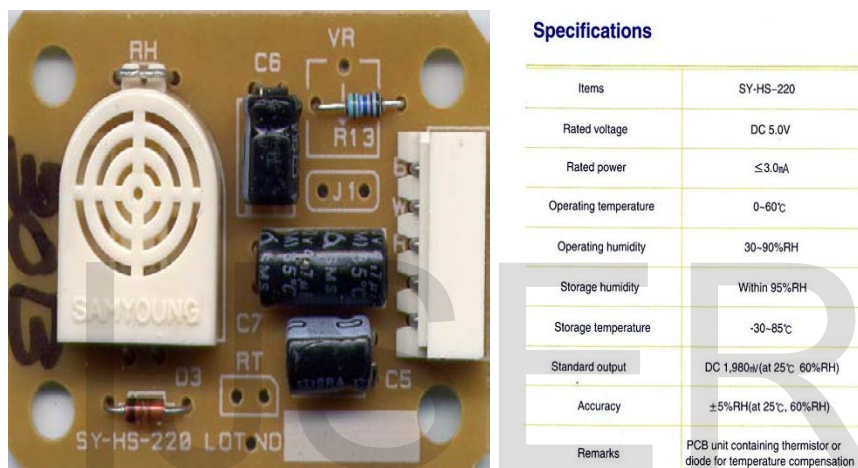

**FIG 3: HUMIDITY SENSOR SY-HS-220**

Humidity sensor senses the change in humidity. If the humidity sensed is below the set limit, the controller unit will turn on the dehumidifier. Once it reaches the set limit it will switch on the humidifier.

### C) LIGHT SENSOR:

A light dependant resistor also known as a LDR, photo resistor, photoconductor or photocell, is a resistor whose resistance increases or decreases depending on the amount of light intensity. LDRs (Light Dependant Resistors) are a very useful tool in a light/dark circuits. LDRs can have a variety of resistance and functions. For example it can be used to turn on a light when the LDR is in darkness or to turn off a light when the LDR is in light. It can also work the other way around so when the LDR is in light it turns on the circuit and when it's in darkness the resistance increases and disrupts the circuit.

The way an LDR works is that they are made of many semi-conductive materials with high resistance. When light falls on the semi conductive material it absorbs the light photons and the energy is transferred to the electrons, which allow them to break free from the crystal lattice and conduct electricity and lower the resistance of the LDR.



**FIG 4: LIGHT DEPENDENT RESISTANCE**

Light dependant resistors have many uses; many of the uses have to do with objects that have to work in certain levels of light. Some of the uses of the LDR are in photographic lightmeters, streetlights and various alarms' light burglar alarms, fire alarms and smoke alarms [24].

LDR senses the change in input intensity of light. If the intensity of light sensed is below the low limit set, the controller unit will switch on bulb. Once it reaches the set limit it will switch off the bulb. In this way, intensity of light is controlled.

**D) SOIL MOISTURE SENSER:**

Irrigation water management requires timely application of theright amount of water. Competition for water, high pumpingcosts, and concerns for the environment are making good watermanagement more important. Managing irrigation water needsto combine a method of measuring soil moisture with somemethod of irrigation scheduling.

Measuring soil moisture detects if there is a water shortage thatcan reduce yields or if there is excessive water application thatcan result in water logging or leaching of nitrates below the rootzone. Measuring soil moisture also can build an awareness andknowledge of each irrigated field that is invaluable for planningand management.Monitoring soil moisture levels is required for effective irrigationwater management. Many tried and proven methods of estimatingor measuring soil moisture are available. The methodselected depends on a variety of factors such as accuracy, cost and ease of use [25].

The Soil Moisture Sensor is used to measure the volumetric water content of soil. This makes it for performing experiments in courses such as soil science, agricultural science, environmental science, horticulture, botany, and biology.



**FIG5: SOILMOISTURESENSOR**

SOIL TYPE	INCHES WATER PER FOOT SOIL
Fine soil	0.7-1.0
Loamy soil	0.9-1.5
Sandy loams	1.3-1.8
Loams	1.8-2.5
Silt loams	1.8-2.6
Clay loams	1.8-2.5
clays	1.8-2.4

**Table: 1 AVAILABLE WATER CAPACITIES FOR VARIOUS SOIL TYPES**

Figure 5 shows the proper placement of the Soil Moisture Sensor. The prongs should be oriented horizontally, but rotated onto their side – like a knife poised to cut food – so that water does not pool on the flat surface of the prongs. The horizontal orientation of the sensor ensures the measurement is made at a particular soil



depth. The entire sensor can be placed vertically, but because soil moisture often varies by depth, this is not usually the desired orientation. To position the sensor, use a thin implement such as a trowel to make a pilot hole in the soil. Place the sensor into the hole, making sure the entire length of the sensor is covered. Press down on the soil along either side of the sensor with your fingers. Continue to compact the soil around the sensor by pressing down on the soil with your fingers until you have made at least five passes along the sensor. This step is important, as the soil adjacent to the sensor surface has the strongest influence on the sensor reading [26].

#### E) ADC:

Many of us consider the ADC to be a mysterious device. It can, however, be considered very simply to be the instrument that it is: a device that provides an output that digitally represents the input voltage or current level. Because the Analog-to-Digital Converter (A/D Converter or ADC) has both analog and digital functions, it is a mixed-signal device. Most ADCs convert an input voltage to a digital word, but the true definition of an ADC does include the possibility of an input current. An ADC has an analog reference voltage or current against which the analog input is compared. The digital output word tells us what fraction of the reference voltage or current is the input voltage or current. So, basically, the ADC is a divider circuit [27].

ADC converters are used for the reverse process of changing analog signals to equivalent binary signals. ADC might be used to change analog output signals from transducers (measuring temperature, pressure, vibration, etc.) into equivalent digital signals. An ADC is often referred to as an encoding device [28]. The designed system uses IC 741.



**FIG 6 DESIGNED SYSTEM**

**X) OBSERVATIONS:**

**A) Temperature at Different Time of a day:**

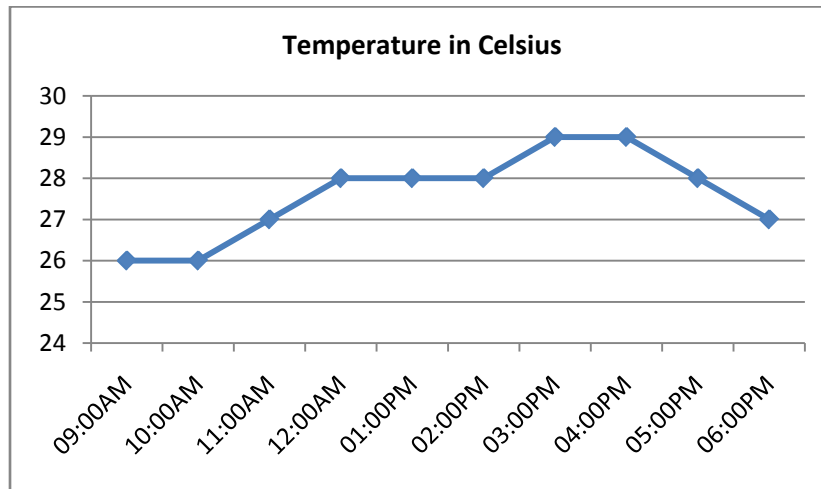

**GRAPH 1**

From the above graph, it indicates that for at different time as per environment conditions temperature sensor J-type thermocouple gives different readings.

**B) Humidity at Different Time of a day:**

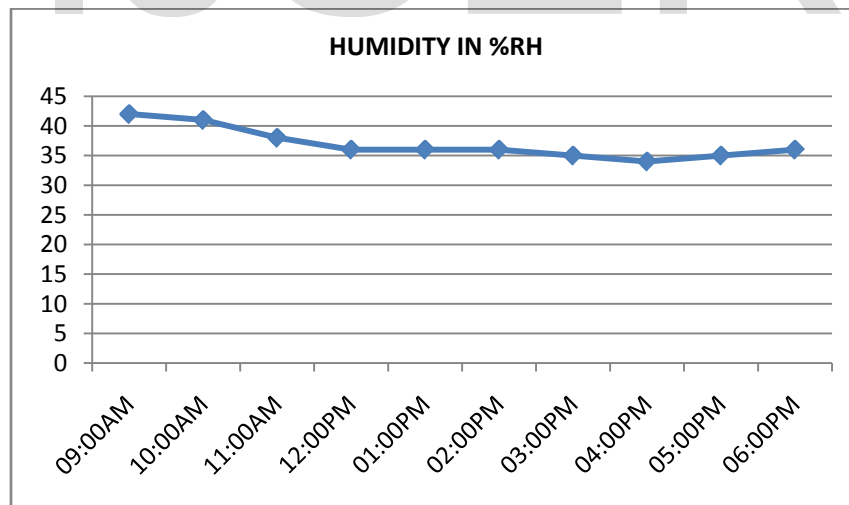

**GRAPH 2**

From the above graph, it indicates that for a different time as per depending on water molecules content in and as per environmental conditions humidity sensor SY-HS-220 gives different readings. In between 12 PM to 4PM humidity is minimum.

### C) Moisture at Different Time of the day:

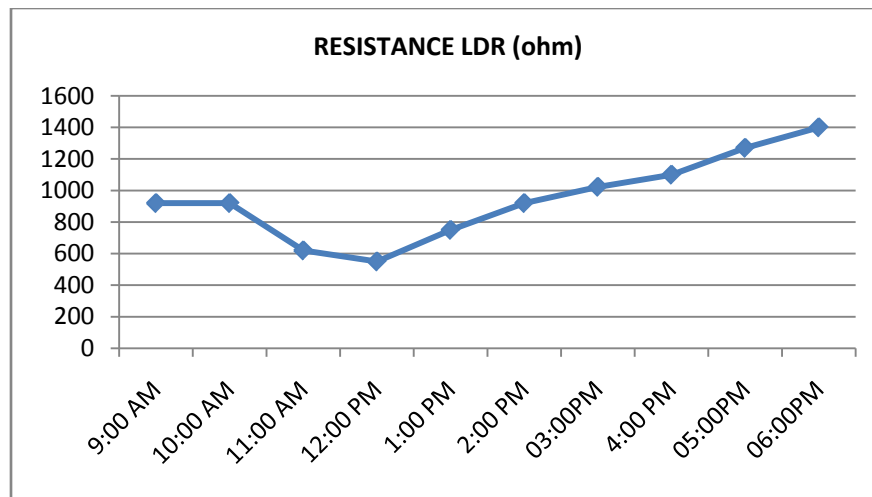

GRAPH 3

From the above graph, it indicates that at different time as per environmental conditions soil sensor gives different readings. At 12 pm water content is very low.

### D) Observations for Soil Moisture Sensor:

The conductivity of soil depends on water contents. It is observed that when there is no water in the soil conductivity is less and motor is turned on and water is spread in the soil. When there is enough water in the soil the conductivity is more between the two probes and the motor is turned off.

### XI) RESULTS:

An experiment is done to record the temperature, humidity, light intensity and soil moisture readings in greenhouse. The reason for this experiment is to make sure that the system that was designed is functioning well and the data can be recorded correctly. Advantages of this system are: it is relatively simple to design and install. This is very useful to all-climatic conditions. It is economic friendly. This makes increase in productivity and reduces water consumption. This is safest and no manpower is required. Reduces soil erosion and nutrients leaching. May be concealed to maintain the beauty of the landscape, and to reduce vandalism and liability when installed in public.

### XII) CONCLUSION:

Green house prevents the plants from the effects of climate; inspect and so on, which makes great sense for agricultural production. The automation and high efficiency on greenhouse environment monitoring and control are crucial. Applying new technologies to greenhouse is a revolution for protected agriculture which overcomes the limits of wire connection systems. Such a system can be easily installed and maintained.

### XIII) ACKNOWLEDGEMENTS:

Author gratefully acknowledges the generous help of H.O.D Dept of Physics, New Arts, Commerce and Science College, Parner (M.S), India for constant guidance and assistance during my work. Author is also thankful to Dr.S.B.Iyyer, the Head of Physics Dept, and Ahmednagar College for providing necessary facilities during work.



#### XIV) REFERANCES:

- 1) C.LDai, M.C.Liu, F.S.Chen, C.C.Wu, M.W. Chang, A “Nanowire WO<sub>3</sub> Humidity Sensor Integrated with Micro-Heater and Inverting Amplifier Circuit on Chip Manufactured Using CMOS-MEMS Technique”. *Sens. Actuators B Chem.* (2007), 123, 896–901.
- 2) Boltshauser, T.; Schonholzer, M.; Brand, O.; Baltes, H. “Resonant Humidity Sensors Using Industrial CMOS-Technology Combined with Post processing.” *J. Micromech. Microeng.*,2(1992) 205–207.
- 3) Okcan, B.; Akin, T. A, “Low-Power Robust Humidity Sensor in a Standard CMOS Process.” *IEEE Trans. Electron Devices*, 54(2007) 3071–3078.
- 4) Trankler, H.R.; Kanoun, O. “Recent Advances in Sensor Technology”. In *Proceedings of the 18<sup>th</sup> IEEE IMTC, Budapest, Hungary*, (2001)309–316.
- 5) Amit Radhakrishnan, Poonam Bansal, Prabhat Kumar, Smitha P, Chinmayananda Das and Ricky, “Monitor and Controlled of Greenhouse Environment”.
- 6) G. R.Senguthar, “Greenhouse Automation System using PSOC<sub>3</sub>” *J. inform.Know. Res. Comm. Engine.* ISSN: 0975-67791 ,(2013)(2)2779-784
- 7) A. Salleh, M. K. Ismail, N.R Mohamad, M. Z.A.Abd Aziz, M.A.Othman, M.H. Misram “Development of Greenhouse Monitoring using Wireless Sensor Network through Zigbee Technology”, *Int. J. Engin. Sci. Inven*, (2)7(2013) 06-12.
- 8) J.H Shin, W.S Hahn, and Y.M. Lee, “Development of the Environmental Control Network System in Greenhouse”, *Agriculture Information Technology in Asia and Oceania*,( 1998) 82-83.
- 9) H.Pohlheim, A.Heibner “Optimal Control of Greenhouse climate using Real-World Weather Data and Evolutionary Algorithms”. *GECCO’99*, pp 1672-1677.
- 10) M. Omid “A Computer Based Monitoring System to Maintain Optimum Air Temperature and Relative Humidity in Greenhouses” *int. j. agri.Bio.*,(06)5 (2004) 869-873.
- 11) A. Goswami, T Bezboruah and K.C.Sarma “Design of an embedded system for monitoring and controlling temperature and light”, *Int. J. Electro. Engin. Res.*, (2009)(1)1, 27-36.
- 12) S.H.Sadati, A.M Sahara, “Design and Simulation of an automated system for greenhouse using Lab VIEW “*American-Eurasian J.Agric and Environ Sci*, 3(2) (2008)279-284.
- 13) Sushma Arjun Kolhe and S A Annadate, “Implementation of Greenhouse Automation using ARM7 Controller” *International Journal of Computer Application*, (47)20 (2012) 0975-888.
- 14) U. A. Waykole, D. G. Agarwal, “Greenhouse Automation System”, *I<sup>st</sup> International Conference On Recent Trends In Engineering and Technology*, March-2012, Special Issue of *International Journal of electronics, Communication and Soft Computing Science and Engineering*,ISSN:2277-9477,2012, 161-166.
- 15) A.V.Mancharkar “Development Comparison and Simulation Studies of Universal Sensor Interface”, PhD thesis, (2005).
- 16) B C Nakara, K K Chaudhary “Instrumentation, Measurement and Analysis” 2<sup>nd</sup> edition, Tata Mc Graw –Hill Publishing Company Limited.
- 17) Richard M Park “Thermocouple Fundamentals”, chief Engineer Marlin Manufacturing Corporation Cleveland, Ohio, U.S.A, Marlin Course # Tech Temp 2-1.
- 18) Stetter, J.R.; Penrose, W.R.; Yao, S. “Sensors, Chemical Sensors, Electrochemical Sensors, J.Electrochem.” *Soc.* 150(2003)11.
- 19) Carr-Brion, K. “Moisture Sensors in Process Control”; Elsevier Applied Science Publishers: London, UK, (1986).
- 20) Kassas, A “Humidity Sensitive Characteristics of Porous Li-Mg-Ti-O-F Ceramic Materials” *Am. J. Anal. Chem.* 04(2013) 83–89.
- 21) Wang, K.; Qian, X.; Zhang, L.; Li, Y.; Liu, H. “Inorganic-Organic P-N Heterojunction Nanotree Arrays for a High-Sensitivity Diode Humidity Sensor.” *ACS Appl. Mater. Interfaces* 5(2013) 5825–5831.

- 22) Kulwicki, B. "Humidity Sensors." J. Am. Ceram. Soc. 74(1991) 697–708.
- 23) B. P. Ladgaonkar, A. M. Pawar, "Design and implementation of sensor node for Wireless sensors network to monitor humidity of High-tech polyhouse environment" Int. J. Adv. Engin. Techno.(2)(2011)1-11
- 24) [http://www.electronics-radio.com/articles/electronic\\_components/resistors/light-dependent-resistor-ldr.php](http://www.electronics-radio.com/articles/electronic_components/resistors/light-dependent-resistor-ldr.php).
- 25) Hal Werner "Measuring Soil Moisture for Irrigation Water Management", Extension Irrigation engineer <http://agbiopubs.sdstate.edu/articles/FS876.pdf>
- 26) S.W. Millikan Way "Soil Moisture Sensor" 13979•Beaverton, OR 97005-2886 [info@vernier.com](mailto:info@vernier.com) [www.vernier.com](http://www.vernier.com)
- 27) Nicholas Gray, "National ABC of ADCs", Data Conversion Systems, June 27, 2006.
- 28) H S Kalsi, "Electronic Instrumentation" second edition, Tata Mc Graw –Hill Publishing Company Limited.(2004)

IJSER