

Beam Port Leakage Problem in the BAEC TRIGA Mark-II Research Reactor and the Corrective Measures Implemented

A. Zahed Chowdhury¹, M A Zulquarnain², A Kalam², A Rahman², M A Salam², M A Sarder², M R I Khondoker², M M Rahman²

Abstract—The 3MW TRIGA Mark-II research reactor (RR) of Bangladesh Atomic Energy Commission (BAEC), which has been in operation since 1986. It has four Beam Ports (BPs). Two of the BPs remained plugged with the beam port plugs (mainly a graphite shield plug) for about 23 years. When Beam Port plugs were removed, it was found to be leaking in Radial BP-1 and Leakage of water came to the notice of the reactor operation personnel after a couple of days. The leak developed due to corrosion was found in the aluminum part of the BP which is located inside the reactor pool at a depth of about 8 m. Condensate accumulated in the annular space between the graphite plug and inner wall of the aluminum beam port initiated the corrosion. Finally, water leakage was stopped by installing a split type encirclement clamp (STEC) around the damaged part of the BP by some remote handling mechanisms, designed and fabricated locally. The paper presents in detail the description of the leakage problem, root cause analysis and the remedial measures implemented so as to make the reactor operational again for normal operations.

Index Terms— Beam Port (BP), Graphite Plug, Split Type Encirclement Clamp (STEC)

1 INTRODUCTION

BAEC TRIGA Mark-II research reactor (RR) is a light water cooled, graphite reflected reactor, designed for steady state and square wave operation up to a power level of 3 MW (thermal) and for pulsing operation with a maximum pulse power of 852 MW. The reactor achieved its first criticality on 14 September 1986, and was commissioned at full power of 3 MW in the same year. Since then, it has been used for manpower training, radioisotope production and various Research & Development activities in the field of neutron activation analysis, neutron radiography and neutron scattering. The RR has four beam ports (BPs), namely tangential BP, radial piercing BP, radial BP #1 (RBP-1) and radial BP #2 (RBP-2). Fig. 1 shows the location of the BPs in the reactor shield structure and Fig. 2 shows the details of the radial BP. It is to be noted [1] that the parts of the BP located inside and immediate outside of the reactor pool liner are made of Type 6061-T6 aluminium alloy and its remaining part is made of Type 304 stainless steel. The tangential BP and the radial piercing BP have been in use for neutron radiography and neutron scattering respectively since early 90s. But RBP-1 and RBP-2 which have never been used for

any purpose remained plugged with various types of removable shield plugs provided by the reactor supplier. The BP plugs mainly consist of (1) an outer and (2) an inner plug made of stainless steel, lead and graphite layers. The outermost end of the BPs is fitted with sliding lead shutters having a diameter of 25.40cm and a thickness of 24.14 cm.

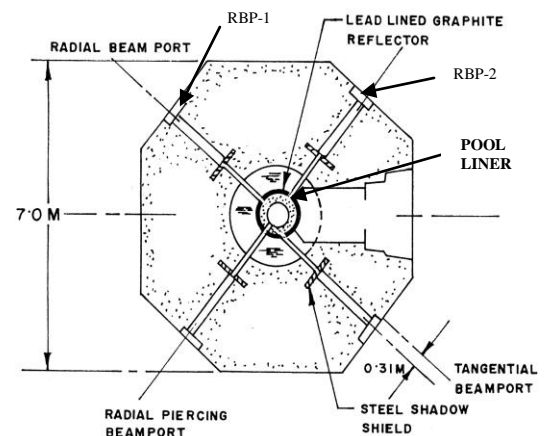

Fig.1. Location of Beam Ports in Reactor Shield Structure

¹A Zahed Chowdhury, Lecturer, Department of Applied Physics, Electronics and Communication Engineering, University of Chittagong, Bangladesh.

Ex-scientific Officer, Reactor Operation and Maintenance Unit (ROMU), AERE, Bangladesh Atomic Energy Commission, Dhaka.

E-mail address: zahedcu12@gmail.com

² Reactor Operation and Maintenance Unit (ROMU), AERE, Bangladesh Atomic Energy Commission, Dhaka.

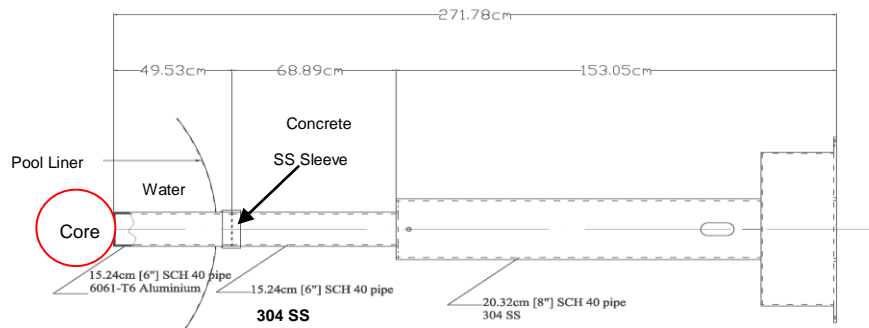

Fig. 2. Details of the Beam Port #1

In 2009, i.e., almost 23 years after the commissioning of the RR, it became necessary to remove the BP plugs from inside the RBP-1 so as to facilitate installation of the collimator of the newly procured high resolution powder diffractometer (HRPD). While doing this, the graphite plug which was the innermost part of the beam port shielding arrangement was found to get stuck very tightly to the aluminium part of the BP-1. The stuck graphite plug was removed by cutting it with the help of locally designed and fabricated special hand tools. While performing the removal operation, extreme care was taken such that the aluminium BP pipe did not get damaged and also the amount of graphite dust produced could be kept at minimum [3].

2 STUDY OF THE CORROSION LEAKAGE PROBLEM

After a couple of days the stuck out graphite plug was removed, reactor pool water was found to have been leaking through the beam port. Leakage of water was stopped by putting a rubber strap around the leaking part of the RBP-1. Efforts were then made to carry out visual inspection of the beam port using a digital camera and at the same time develop a device that could be used to solve the water leakage problem.

2.1 General layout and location of the damage

As shown in Fig. 2, the aluminium part of the RBP-1 which has a length of 48.26cm pierces the reactor pool liner and terminates near the outer surface of aluminium liner of the reactor core. The end of the beam port tube is closed with a 6.125cm thick aluminium disc. The graphite plug occupied about 34.29cm of the aluminium pipe. Therefore about 15.24cm of the aluminium pipe of the beam port from its dead end remained void. The reported leaks developed from corrosion damage mainly took place on the inner bottom surface of the aluminium pipe located at distances from 15.24cm to 35.56cm from the dead end of the RBP-1. Corrosion damage also occurred to some extent on the stainless steel pipe and at the aluminium-steel interface.

2.2 Visual inspection

The graphite plug removed from the RBP-1 was wrapped with a polyethylene sheet and stored in a wooden box.

Upon visual inspection, water condensate was visible inside the polyethylene sheet. This clearly indicated that the corroded part of the graphite plug absorbed moisture from the condensate that had accumulated in the annular space between the plug and the beam port tube. Deposits or scales were found on the outer surface of the lead plug and these deposits consist of species resulting from the corrosion. Photographs obtained from a digital camera inserted into the RBP-1 clearly showed the corrosion damages in the form of metal removal and pits on the inner bottom surface of the aluminium pipe. It also revealed that the damage in the form of pits had initiated at the interface between the stainless steel aluminium. Brown stain marks were observed on the stainless steel surface but no pits or metal removal was found on the stainless steel surface as shown in Fig. 3.



Fig. 3. Inner surface beam port

2.3 Scanning electron microscopy and EDX analysis

Samples of corrosion products, debris, deposits, etc. were collected from inner surface of the aluminium part of RBP-1. The specific radio activities of these samples were found to be quite high, and as such, these could not be examined. However, scanning electron microscopy and energy dispersive x-ray (EDX) analysis of the deposits collected from the surface of the lead plug were performed in the Department of Materials and Metallurgical Engineering (MME), Bangladesh University of Engineering and Technology (BUET), Dhaka. The results showed the

presence of oxygen, carbon, lead, silicon and aluminium. The friable and porous nature of some of the debris indicated the presence of hydroxides in it. It is to be mentioned that BUET had been involved to study the problem and make recommendations to BAEC for remedial measures to be undertaken. BUET report pointed out [2] that the aluminium (Al) pipe of the RBP-1 suffered extensive damage as a result of corrosion caused due to the presence of air and moisture inside the beam tube. It also attributed that damages in terms of corrosion had been initiated at the aluminium-stainless steel interface where a stainless steel (SS) sleeve had been used to cover the circumferential gap between the SS and Al pipes. It is to be noted that the interface sleeve was not wrapped with sealant during installation. As a result water vapour from the surrounding concrete found its way to condense into the gap between the graphite plug and aluminium pipe. Later these moistures initiated the corrosion process onto the aluminium pipe. The continual presence of moisture transformed the otherwise protective aluminium oxide layer into aluminium hydroxide, which is porous and cannot prevent air and moisture to seepage through it and attack the fresh aluminium underneath. The cracks and/or pits resulted from corrosion went through the aluminium pipe inter-granularly and allowed water from reactor tank to sip through and drain out of the beam port. The rubber sleeve used underneath the aluminium pipe temporarily sealed the mass flow of water from reactor tank and stopped water seepage through the beam port.

3 RECTIFICATION MEASURES IMPLEMENTED

The above mentioned BUET report recommended several actions including installation of an outside aluminium sleeve so as to protect the outer surface of the aluminium pipe and seal the flow of water from the reactor tank into the beam port. In line with the recommendation, a split type encirclement clamp (STEC) with silicone rubber lining as shown in Fig. 4, was designed and fabricated locally using Type-6061 aluminium alloy. The STEC was then installed around the segment of the RBP-1, which is located inside the reactor pool at a depth of about 8m by using remotely operated nut-tightening tools which were designed and fabricated locally.



Fig. 4. Split type encirclement clamp (STEC)

The STEC has been designed and fabricated with provision such that it can be dismantled for replacement of the silicone lining and reinstalled again. About 48 hours after installation of the STEC, the inside of the RBP-1 was inspected with a camera and no trace of water was found. It is to be noted here that approval of the regulatory authority was undertaken before implementing the above mentioned rectification measures, and also that several fuel elements had been removed from the part of the reactor core that was in the line of sight with the RBP-1 such that radiation streaming from the core could be minimized. The job was implemented under constant supervision of the Radiation Control Officer responsible for the research reactor and the Reactor Supervisor/Reactor Manager.

4 CONCLUSION

The beam port leakage problem of the BAEC research reactor was a vital issue that could lead to a situation even close to a LOCA (loss-of-coolant accident). It is reported that the leakage problem results from the corrosion caused due to the presence of air and moisture inside the beam tube. The stainless steel (SS) sleeve used at the circumferential gap between the SS and Al pipes was not wrapped with sealant. As a result water vapour from the surrounding concrete got a way to condense into the gap between the graphite plug and aluminium pipe. Thus the continual presence of moisture transformed the otherwise protective aluminium oxide layer into aluminium hydroxide. It cannot prevent air and moisture to seepage through it and attack the fresh aluminium underneath. Finally the matter was handled carefully taking all measures so that such a thing could be prevented from happening. Assurances of agencies outside BAEC were taken for solving the problem. It is understood that the silicone rubber lining of the encirclement clamp may get damaged because of neutron irradiation. Therefore, while designing the clamp, provisions were kept such that it can be dismantled and reinstalled again with the lining replaced by a new one.

REFERENCES

- [1] GA Document No. GA-A17054, "Mechanical Operation and Maintenance Manual," General Atomics Project 2299, (May 1984).
- [2] "Report on Probable Solution for Corrosion of Aluminum Tube of Radial Beam Port # 1 and #2 of the 3MW TRIGA Mark-II Research Reactor of Bangladesh Atomic Energy Commission (BAEC), Savar"; Department of Materials and Metallurgical Engineering, Bangladesh University of Engineering and Technology (BUET) Dhaka 1000, Bangladesh.
- [3] International Atomic Energy Agency, Ageing Management for Research Reactors, Safety Guide NS-G-4.7, IAEA.