

Smart Grid-A Pragmatic Vision for Blackout Free Future

Salil Mittal, Yash Maheshwari, Apurv Pratap Singh, Ayush Varshney, Surbhi Agarwal

Abstract—Smart Grid is an emerging and promising technology that will prove inalienable in the near future. The need for improvement of efficiency of electricity transmission and distribution can be achieved to a greater extent with the use of smart grids. This paper deals with the features a grid should have, need of Smart Grids, Smart Grids and its key features such as Self Healing, Bi-Directional flow of electricity, and the problems it can solve. Paper gives a detailed overview of various technological components of smart grid like Distribution Automation, Personal Energy Management and Advanced Metering Infrastructure. The paper also puts through the visualisation of electricity theft tracking and its stoppage. The urge to move onto an economically feasible and efficient grid technology is put forward and the visualised infrastructure of the Smart Grids is included. The Self Healing technique, as the name suggests, is a unique feature which incorporates grid communication thus help in rectifying any fault in electric grids in no time which has been rightly put forward in the paper. Also it would help in reduction of harmful emissions to the environment by reducing power loss. Bi-Directional flow of electricity is the inducement of dual relationship between the User and the Provider, thereby helping in the decentralisation of electricity production. Finally, the visualised application of Smart Grids is in electrical theft tracking. This would help in reducing large economic losses suffered by Indian electricity board and raising the quality of supply at the user end. The effective implementation of this application would help in building a smarter future.

Index Terms— Smart Grids, Self Healing, Bi-Directional Flow, Peak management, Distribution Automation, Personal Energy Management, Advanced Metering Infrastructure, Electrical theft tracking.

1 INTRODUCTION

Advancement in technology demands a smart change in traditional power grid. Smart Grid is the most promising option for future, surpassing most of the substantial advantages of traditional grid. Having a glance at the power problems today like blackouts, outages, overload, transformer blowing up and defects like that leads us to find some way to tackle these setbacks smartly. Introduced in 2005, Assortments of smart grid includes electronic grid, smart meters, wireless connectors etc which together used as an arsenal to tussle the traditional grid drawbacks.

Smart grid is a type of electrical grid which attempts to predict and intelligently respond to the behaviour and actions of all electric power users connected to it in order to efficiently deliver reliable economic and sustainable electrical services. Smart grid has a well-built communication at each point in the system. Smart grid incorporates its unique feature in existing power grid like Real time management, Bidirectional flow, self healing, and Peak hour analysis [1]. Moreover, Smart grid helps us to decarbonise the power

sector resulting in pollution free world. Moreover, introduction of the smart grid in the system boost up the utilisation of renewable energy manifolds.

On the whole smart grid is the new face of technology in the domain of electrical engineering and our paper is a simplest way of taking you to this smarter journey of the future with a slight introduction to the challenges faced by this remarkable future grid and it's after effect in shaping our dream world with no blackouts and energy losses anymore.

2 NEED OF SMART GRID

Electrical energy today became one of the most basic needs of human life. Nearly everything is operated with the help of electricity. Current grid no doubt have served well but according to International Energy Agency (IEA), European electricity consumption is projected to increase at an average annual rate of 1.4% up to 2030 and so does for our country India and all over the world. Henceforth, Grid should include the new technology so as to tussle and curb out the problems of electricity generation, distribution and transmission thereby fulfilling the demands. Albert Einstein rightly said that "We can't solve problems using the same kind of thinking, we use when we created them". And quoting his words here clearly outlined the fact that to rectify the drawbacks of today's grid we have to bring something fresh and smarter which is what exactly Smart Grid is. Before proceeding let us see what are the basic features a grid must have.

2.1 Basic Features Grid Must Have

2.1.1 Flexible:

Fulfilling customers needs whilst responding to the changes

- Salil Mittal is currently pursuing bachelors degree program in electrical engineering in Zakir Hussain College of Engineering and Technology (AMU), India. E-mail: mittalsalil.2701@gmail.com
- Yash Maheshwari is currently pursuing bachelors degree program in electronics engineering in Zakir Hussain College of Engineering and Technology (AMU), India. E-mail: ayashdangra@gmail.com
- Apurv Pratap Singh is currently pursuing bachelors degree program in electrical engineering in Zakir Hussain College of Engineering and Technology (AMU), India. E-mail: apurvsngh643@gmail.com
- Ayush Varshney is currently pursuing bachelors degree program in electronics engineering in Zakir Hussain College of Engineering and Technology (AMU), India. E-mail: aayush.18@hotmail.com
- Surbhi Agarwal is currently pursuing bachelors degree program in electronics engineering in Zakir Hussain College of Engineering and Technology (AMU), India. E-mail: surbhiagarwal68@gmail.com

and challenges ahead.

2.1.2 Accessible:

Providing connection access to all network users. The electricity should reach every remotely accessible area analogous with that area's resources of electricity production either it be renewable or non-renewable.

2.1.3 Reliable:

Assuring and improving security and quality of supply, consistent with the demands of the digital age with resilience to hazards and uncertainties in approach.

2.1.4 Economic:

The provision should not be at an exorbitant price but should be at an affordable price so that everyone would be able to take its benefits [2].

2.2 Need of Smart Grid

2.2.1 For Security of Supply:

The Electricity Transmission needed to be highly reliable with least power failures in electrical transmission in contrast to today's grid where power failures are nothing new in the scene. The voltage provided at the user end should be nearly constant with negligible fluctuations so as to not affect the grids and meters adversely, which is completely overlooked by today's grid. The quality of supply should be good caused by incorporating good network and increasing generation capacity (taking in renewable resources into account) which lacks in today's grid.

2.2.2 Environmental Issue:

Global warming, melting away of polar ice and such other concerned issues which are directly or indirectly caused by the large emission of CO₂ and other harmful gases emitted by power plants, which is the main producer of electricity today, raises a question in our mind- At what cost are we enjoying

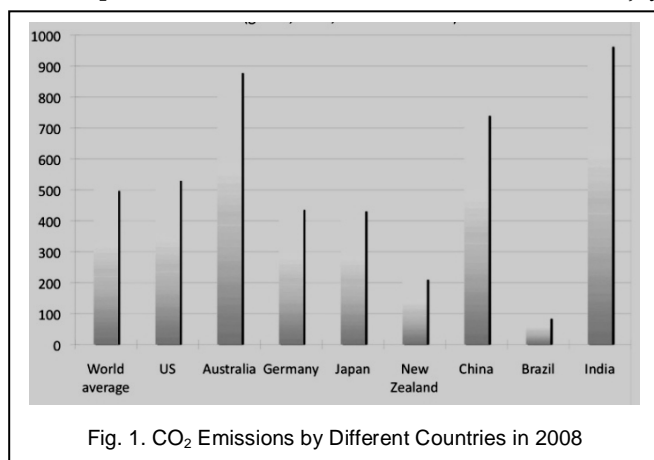

Fig. 1. CO₂ Emissions by Different Countries in 2008

this liability provided to us? Therefore we need to find a smarter way to decarbonise our power to some extent [3].

2.2.3 For Distributed Generation (DG) and Renewable Energy Sources (RES):

There is a need to understand and manage the technical chal-

lenges and look out for surging in new generation technologies into today's grid. The centralisation of electricity production leads to an accumulation of the problems within the segment, thereby making it loathsome to curb out those problems. Also today's grids lack in an inevitable feature in today's world scenario i.e. inclusion of renewable energy sources with the traditional sources. We need to decentralise the power system so that it can enhance the use of renewable resources in electricity production manifolds.

2.2.4 Lacking Demand Response and Demand Side Management (DSM) in today's Grid:

Raising Efficiency of transmission and distribution or inclusion of renewable resources are not the only goals that has to be incorporated rather a good management of electricity usage equally accounts for the betterment of electrical grids. The consumer's demand has to be a prime concern as they are the financial terminals of a grid.

2.2.5 Need of Powerful Communication:

There is a need of a well built communication system so as to make the grid coherent with the changing needs of the generation. There is a need to include interactive softwares in the existing grids so as to ease the detection of faults or any type of discrepancy in the grids. The lack of communication leads to a huge economic loss.

The recent infamous 2012 Blackout that affected nearly 620 million people in Northern, Eastern and North Eastern India and lead to a shutdown of uncountable companies due to lack of awareness of deteriorating conditions clearly depicts the pathetic condition of communication technique in today's grid. The occurrence of huge losses due to such events has to be avoided wherein the role of smart grids comes.

3 SMART GRID

"Smart grid" generally refers to a class of technology people are using to bring utility electricity delivery systems into the 21st century, using computer-based remote control and automation. These systems are made possible by two-way communication technology and computer processing that has been used for decades in other industries. They are beginning to be used on electricity networks, from the power plants and wind farms all the way to the consumers of electricity in homes and businesses. They offer many benefits to utilities and consumers -- mostly seen in big improvements in energy efficiency on the electricity grid and in the energy users' homes and offices. Technically smart grids co-ordinate the needs and capabilities of all generators, grid operators, end-users and electricity market stakeholders to operate all parts of the system as efficiently as possible, minimising costs and environmental impacts while maximising system reliability, stability and resilience to faults or any damage [4]. It is an emerging set of technologies that will be plummeted at different rates in cities at variable settings analogous to the existing technology, investment web and commercial attractiveness of the area under consideration. Investments in a number of adjuncts are inevi-

table to support the use of the primary assets for smart grid applications, hence the function of a smart grid. Some of these assets are described below.

3.1 Related to Communication Induction

For this we require wide-area communications networks, servers, gateways, smart meters (commonly termed as basic advanced metering infrastructure (AMI) technology), with shorter metering intervals approaching 5 minutes or less to support provision of distribution capacity management etc. It also requires full two-way communications between the home area network and the smart appliances for asset optimization and demand response.

3.2 Related to Bi-Directional Flow

For this we require high scale management control systems of local-area homes, commercial buildings, and industrial energy providers, consumer information interfaces and decision support tools. It also requires smart accounting tools at the user as well provider end.

3.3 For Demand Response and Demand Side Management

It requires softwares for advanced billing systems- its accountability and predictable usage. It also requires remote connection/disconnection provision as per the need of the user.

3.4 For Cyber Security

It requires cyber-security technologies for secure communications for all levels of operations, associated standards and protocols that focus on communications between the various SCADA controlled domains inherent in the smart grid: includ-

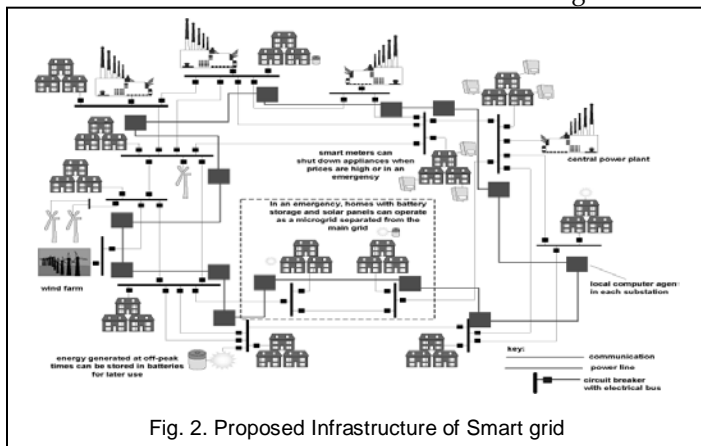

Fig. 2. Proposed Infrastructure of Smart grid

ing the Independent System Operator/Regional Transmission Organization utility, customer, and aggregator [5].

4 FEATURES OF SMART GRID

Smart grids are the interface that links us to a smarter planet because of its unique and smart features. Some of which are discussed below.

4.1 Bidirectional flow

Today's grid allows us the only option of consuming electricity from the main supply coming from the power plant, we can in no way send energy to the plant by generating it at our places by using alternative means but with the introduction of the smart grids we would be able to do so incorporating a unique feature known as bidirectional flow induction. It will allow electricity transient between the provider and the consumer in the most profitable way. Consider, if at home we are generating excess amount of electricity by any renewable sources usage say solar energy then we can send it back to the distributors end for its proper utilisation as per need. This way we are not just generating electricity but also transmitting it back to the plants for usage in the areas where it is lacking. It requires an active participation by the Users for putting into usage the renewable resources known. This will obviously encourage the use of renewable energy and as such the decentralisation of power production occur. We as such sitting in our home can earn dollars and simultaneously help our world becoming greener. It is a smart way of saving money and making money.

4.2 Excellent communication network

Technology now exist that could be used to establish a real-time transmission monitoring system therefore introducing a smarter version of today's grid. Electronic grid at each end will not only provide information to the grid but also give its important features like Self Healing. The availability of communication technology like advance software for data management and intelligent and autonomous controllers has opened up new opportunities for changing communication in the grids which bring out the unique features of this grid [6].

- **Interactive:** Appropriate information regarding the status of the system is provided not only to the operators, but also to the customers to allow all key participants in the energy system to play an active role in optimal management of contingencies.
- **Optimized:** Developing strategies for local demand modulation and load control by electronic metering and automated meter management system is also a prime concern for the ease of consumer. Knowing the status of every major component in real or near real time and having control equipment to provide optional routing paths provides the capability for autonomous optimization of the flow of electricity throughout the system. Not only this, a smart grid applies the latest technologies to optimise the use of its assets. For example, optimised capacity can be attained with dynamic ratings via Smart appliances, which allow assets to be used at greater loads by continuously sensing and rating their capacities. Smart appliances may be configured by the end-user to communicate information directly to the utility operator for efficient and more productive use of electricity. It

will help in reducing losses and congestion thereby making it effective. The Efficiency of operation is increased by selecting the least -cost energy deliverance through calculative approach by the utility operator. For example, a 'smart' water heater could be equipped with a device that coordinates with a facility's energy-management system to adjust temperature controls, within specified limits based on energy prices. Understanding how "Smart" households manage energy use better and reduce their carbon footprint. Firstly logging into their energy use account and seeing how much energy they are using in real time, and as compared to their neighbours, as reported by smart meters installed at each household. Secondly, using smart devices, such as a smart thermostat that shows minute by- minute price of energy. The thermostat could be programmed to make decisions about the house's heating and air conditioning levels. If the price of energy is high, and no one is home, the thermostat could be set to adjust automatically to use less energy. Smart appliances could also be programmed to run when energy is cheaper, such as a dishwasher running at night and finally at peak energy usage times, allowing the utility to lower energy consumption of smart devices, such as adjusting a house's air conditioner by a few degrees

- **Self Healing:** Self healing is one of the most remarkable features of smart grid which is primarily because of the smart communication network. This feature will provide grid to communicate and react to any accidents between any two switches (electronic grids) that will smartly analyse and handle the situation by finding an alternate solution through another possible route and provide electricity in the mean time to this area that will obviously mitigate the problem of the complete blackout of the area preventing huge economic losses as such [7].

4.3 Intelligent Electronic Devices

The protection, metering and control functions in substations are naturally distributed by the role and location of each device, being designed in general to provide primary protection or monitoring of individual substation equipment. These functions may be performed by smart multifunctional and communicative units, so-called IEDs. They are broadly defined as the devices incorporating one or more processors with the capability to receive or send data/control signals from or to an external source (e.g., electronic multifunction meters, digital relays and controllers). The IEDs, employing efficient signal processing techniques, are becoming the source of much more information in real time than the one existing in old substations. Algorithms, they can provide externally electrical magnitude measured by protection transformers as well as phase differences among them .Those measurements can be synchronized, both at the substation and wide-area levels, by

means of the GPS satellite clock time reference. Hence this

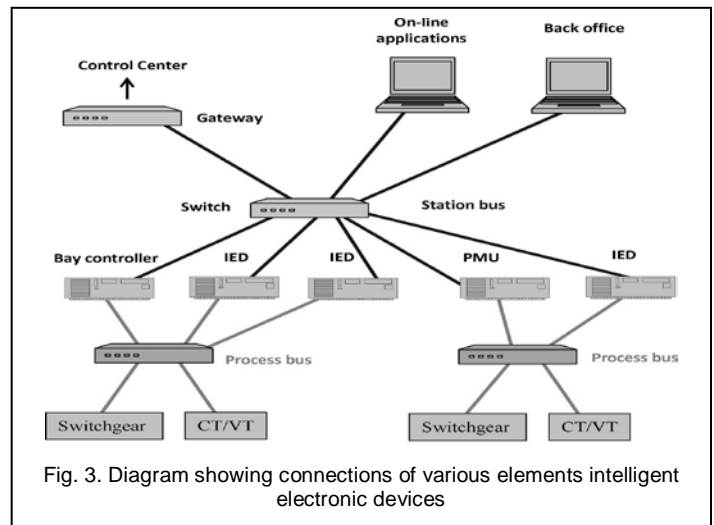

Fig. 3. Diagram showing connections of various elements intelligent electronic devices

feature of smart grid not only point out the faults but also help to trace and recover from them before they became malice to the society [8].

4.4 Managing peak load capacity

It includes displacing the need for new generation, localizing this function to displace the need for new transmission, further localizing it to manage capacity to offset the need for new and upgraded distribution substations and feeders, and managing transformer loading to extend their lifetimes. About 40% of grid infrastructure costs are for generation capacity, which must be adequate to serve peak load demand while maintaining adequate reserves for forced outages and contingencies. In light of growing demand for generation worldwide, environmental constraints on new coal generation, the imposition of renewable generation portfolios by states, and rising costs for steel, concrete, and other materials, and costs for new generation capacity to meet load growth are expected to grow substantially. Another 40% of infrastructure costs are for distribution systems, so the opportunity to manage peak load demand at the substation level is an important opportunity. Peak load management from demand response, distributed storage, and optimization of distribution delivery voltages and power factors can all serve to defer investment in generation, transmis-

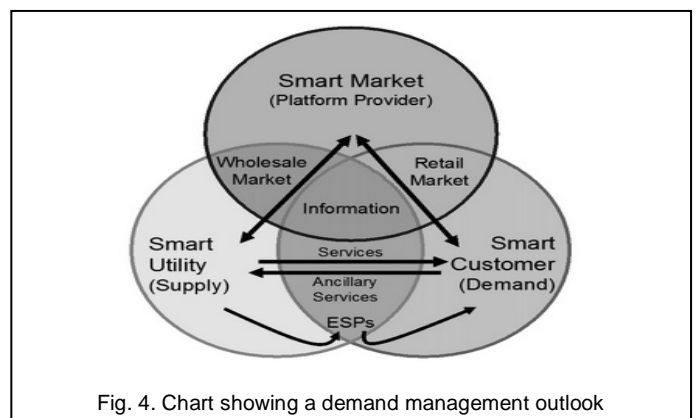

Fig. 4. Chart showing a demand management outlook

sion, and distribution systems. The value stream from this is derived in terms of the avoided carrying costs for investment in new capacity.

5 TECHNOLOGICAL COMPONENTS OF SMART GRID

Any technology that assists the intelligent control of electricity over the grid can be considered a smart grid enabling technology. Under this definition, any communication technology that allows data to be transmitted to and from utilities, grid operators, consumers, and smart devices on the grid and in the home is an enabling technology for the Smart Grid. A communication technology that transmits data in only one direction does not enable the capabilities inherent in the Smart Grid and is not a smart grid enabling technology. In a similar fashion, back-office software that can account for real-time electric usage and bill customers accordingly is a technology that enables the Smart Grid. Billing and accounting software that cannot account for real-time pricing do not enable the Smart Grid. The three key technological components of Smart Grid that includes:

- i. Distribution Automation (DA)
- ii. Personal Energy Management (PEM)
- iii. Advanced Metering Infrastructure (AMI)

5.1 Distribution Automation

Distribution Automation System provides tools for the distribution power network's security, economical operation. It guarantees power quality, perfecting facility management as well as increasing working efficiency and providing a series of solutions for the distribution automation system. The system supplies the function of power grid monitoring, control, failure management, and power balance and charge management. It improves reliability with real-time monitoring and intelligent control [9]. This system is basically head-end network management software. It provides network speed enhancements. Improving efficiency and reliability of a distribution network is a critical goal for many utilities. Two-way communications with the protection and control devices on the distribution portion of the smart grid is fundamental to achieving those energy efficiency and reliability goals. Distribution Automation (DA) devices themselves are evolving to be more robust and reliable, offer higher computing power, and act as a source of planning data. And given utilities' continual focus on improving energy efficiency and power reliability, matching these improvements with real-time communications is a key. Understanding the status of devices like: switches and reclosures, capacitor banks, voltage regulators and transformers in real time enables much faster outage detection and notification and improves fault location and isolation. It also increases energy efficiency through better capacitor and voltage control and improved asset management. Many analysts believe, DA is the secret to making the Smart Grid pay for itself

5.2 Personal Energy Management

Personal Energy Management (PEM) is a critical component of the smart grid. It opens the door for energy consumers to become directly involved in monitoring and controlling energy use. It provides utilities with the tools to more uniformly control peak load, and ultimately support new sources of generation and new uses of electricity. Personal energy management is the future of energy efficiency. This is one of the aspects of the Smart Grid that has only recently begun to emerge: using Home Area Network to engage the energy consumer more directly in the energy management process. Today's advanced metering technology provides a ready communication gateway into the residence or business that didn't exist before. A smart distribution grid requires the means to remotely, securely and automatically capture information, monitor performance, and execute commands that enable efficient and reliable power delivery. Personal Energy Management takes this concept directly to the consumer with a variety of applications for reducing peak load, monitoring alternative generation, managing recharging of plug-in hybrid vehicles and prepayment of electric service [10].

5.3 Advanced Metering Infrastructure

Advanced metering infrastructure (AMI) is architecture for automated, two-way communication between a smart utility meter with an IP address and a utility company. The goal of an AMI is to provide utility companies with real-time data about power consumption and allow customers to make informed choices about energy usage based on the price at the time of use. AMI is not a single technology implementation, but rather a fully configured infrastructure that must be integrated into existing and new utility processes and applications. This infrastructure includes home network systems, including communicating thermostats and other in-home controls, smart meters, communication networks from the meters to local data concentrators, back-haul communications networks to corporate data centers, meter data management systems (MDMS) and, finally, data integration into existing and new software application platforms. Additionally, AMI provides a very "intelligent" step toward modernizing the entire power system.

At the consumer level, smart meters communicate consumption data to both the user and the service provider. Smart meters communicate with inhome displays to make consumers more aware of their energy usage. Going further, electric pricing information supplied by the service provider enables load control devices like smart thermostats to modulate electric demand, based on pre-established consumer price preferences. More advanced customers deploy distributed energy resources (DER) based on these economic signals. And consumer portals process the AMI data in ways that enable more intelligent energy consumption decisions, even providing interactive services like prepayment.

The service provider (utility) employs existing, enhanced or new back office systems that collect and analyze AMI data to help optimize operations, economics and consumer service. For example, AMI provides immediate feedback on consumer outages and power quality, enabling the service provider to

rapidly address grid deficiencies. And AMI's bidirectional communications infrastructure also supports grid automation

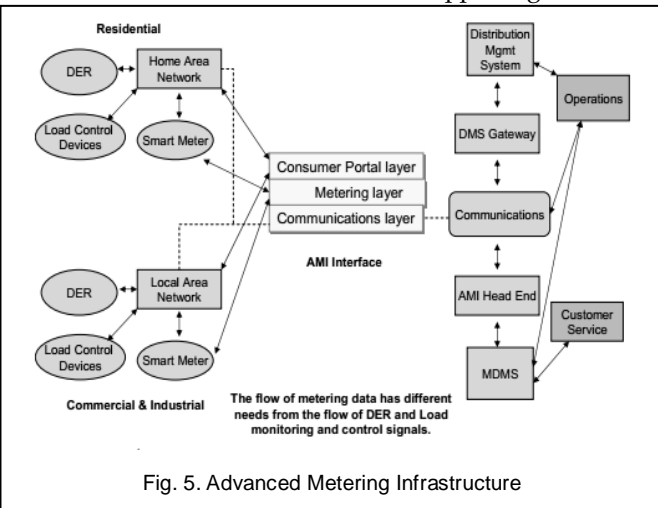

Fig. 5. Advanced Metering Infrastructure

at the station and circuit level. The vast amount of new data flowing from AMI allows improved management of utility assets as well as better planning of asset maintenance, additions and replacements. The resulting more efficient and reliable grid is one of AMI's many benefits.

6 CHALLENGES IN SMART GRID

These advances also generate unprecedented data volume, speed and complexity. Data storage costs can explode due to increased data volumes and retention requirements. To manage and use this information to gain insight, utility companies must be capable of high-volume data management and advanced analytics designed to transform data into actionable insights. For example, designing effective demand response programs requires that utilities execute advanced analytics across a combination of data about customers, consumption, physical grid dynamic behavior, generation capacity, energy commodity markets and weather. Big data analytics seem a promising solution. The field yet is immature and provides challenges to seasoned DBAs in the industry. The fresher outlook of big data demands a more innovative approach in leveraging its advantages to the fullest. Organizing data is open ended and requires the administrator to contemplate over the long term and short term usage of the data [11].

7 ELECTRICAL THEFT TRACKING

Looking at the serious problem of electrical stealing especially in India which cost around hundreds of crore losses, we have thought of introducing a micro grid in the switches supplying electricity to a particular area that can connect and share data with the smart meters installed at consumers end and suppliers end knowing exactly how much energy is being used and supplied. The electronic grid will be much smarter in calculating the power losses in transmission wires, provided with the length of wires and resistivity from the suppliers end. Say Main power supply provide "X" unit energy between two smart grid switches let's say 'a' and 'b'. Smart meters connect-

ed at consumers end between this switches will provide say all together "Y" energy being consumed at the very moment of calculation and "Z" being the power loss in "l" length of transmission wires. Now if after calculations done by the electronic grid there is suppose be a larger variation from the expected "X-Y-Z" energy then our smart electronic grid will alarm the technician at the distribution or substation level to check the connection at that location. This all system requires wireless connectivity between electronic grid to meters, electronic grid to suppliers.

8 CONCLUSION

Changes are an inalienable part of technological improvement. The above discussed points basically picturises the need to introduce smart grid that will not only curb out the problems in today's but also generate more employments, utilisation of renewable energies. The overarching privacy concerns associated with Smart Grid technology are its ability to greatly increase the amount of information that is currently available relating to the activities of individuals within their homes. At the end we should know that some of the systems we have described require communication between various components. Some of these communication links might introduce vulnerabilities, especially if they can be accessed over the Internet. We should not build a power system in which a hacker working for a burglar can tell when you are home by monitoring your control systems or a hacker on the other side of the world can cause system-wide instabilities and blackouts. Many of the designers of these systems offer assurances that they are being built in compliance with all the current security standards. However, such standards have by necessity been developed before a smart grid existed, or a clear consensus has emerged regarding the nature of a smart grid. Thus, serious scrutiny is needed to ensure that such standards are truly adequate. The social vulnerabilities that a "smart grid" may create are receiving far too little attention. Figuring out how to minimize or avoid these vulnerabilities is an issue in urgent need of study.

REFERENCES

- [1] "Understanding the Benefits of the Smart Grid" By NETL, June 18 2010. <http://www.netl.doe.gov>
- [2] "Smart Grid" by Wikipedia. http://en.wikipedia.org/wiki/Smart_grid
- [3] "The Smart Grid: An Estimation of the Energy and CO2 Benefits" By RG Pratt, MCW Kintner-Meyer, PJ Balducci, TF Sanquist, C Gerkenmeyer, KP Schneider, S Katipamula and TJ Secrest- PNNL-19112, Revision 1 January 2010.
- [4] "Smart Grid Concepts and Characteristics" By Edvard. <http://electrical-engineering-portal.com/smart-grid-concept-and-characteristics>
- [5] Smart Privacy for the Smart Grid: Embedding Privacy into the Design of Electricity Conservation November 2009
- [6] "Technology Roadmap to Smart Grids" IEA
- [7] "Vision for a self healing power grid" by Khosrow Moslehi and Ranjit Kumar.
- [8] "The Smart Grid: An Introduction" By Litos strategic communication under contact no.DE-AC26-04Nt-41817, subtask 560.01.04.

- [9] "Distribution System Automation" By Palak Parikh, Ph.D. ES 586b
Course Project Report, Electrical and Computer Engineering Department, University of Western Ontario
- [10] "Smart Grid and its Development Prospects In the Asia-Pacific Region" By Gurlin Singh Lamba, Software Engineer Landis & Gyr,
Journal of Emerging Trends in Computing and Information Sciences
Volume 2 No. 1
- [11] "Environmental Impacts of Smart Grids" by NETL.
www.netl.doe.gov.

IJSER