

Performance Analysis of Orthogonal Frequency Division Multiplexing (OFDM) System by using Peak to Average Power Ratio (PAPR) Algorithm

Md. Selim Hossain, Md. Mahasin Ali, Md. Biplob Hossain, Md. Dulal Haque and Md. Abubakar Siddik
Department of Telecommunication and Electronic Engineering, Hajee Mohammad Danesh Science and Technology University Dinajpur-5200, Bangladesh

Abstract- Orthogonal Frequency Division Multiplexing (OFDM) is an efficient method of data transmission for high speed communication systems. The basic principle of OFDM is to split a high-rate data stream into a number of lower rate streams that are transmitted over a number of subcarriers. OFDM has several characteristics such as providing greater immunity to multipath fading & impulse noise improves the bandwidth efficiency. But, OFDM suffers a serious drawback of high peak to average power ratio (PAPR). There are several methods has been proposed to reduce PAPR, clipping and filtering is one of them. But the existing Clipping and filtering method has in-band and out-band losses that degrade the system performance. So we proposed a new algorithm called pumping based clipping method to reduce these losses and increase system efficiency. In this method the input signal is first pumped by an amplifier circuit that increases only the amplitude but doesn't power of this signal. After that an anti peak signal is generated by Gaussian function. Then the pumping signal is clipped by the anti peak signal to get clipping signal. By pumping the input signal before clipping is reduce the in-band and out-band losses and Peak to Average Power Ratio (PAPR) of the system. Hence the Bit Error Rate (BER) as well as the overall system performance is increased by this method.

Keywords—OFDM, PAPR, Clipping, Bit Error Rate, Pumping Based Clipping, Peak Power and Average Power.

1. Introduction

OFDM (Orthogonal Frequency Division Multiplexing) is a multicarrier modulation technique that is implemented in many recent wireless applications. The basic principle of OFDM is to split a high-rate data stream into a number of lower rate streams that are transmitted simultaneously over a number of subcarriers. OFDM is a special case of broadband multicarrier modulation technique that is to separate the main channel into a lot of orthogonal sub-channels, in which a higher rate single data stream is transmitted over a number of lower rate subcarriers. OFDM offer high spectral efficiency, immune to the multipath delay, low inter-symbol interference, immunity to frequency selective fading and high power efficiency. Due to these merits OFDM is chosen as high data rate communication systems [3]. Whichever kind of amplifier we use, we never get out more energy than we put in. It's true that the output current or voltage may be many times bigger than the input signal, but that doesn't mean we are generating extra energy for free which follow a

Basic law of physics called the conservation of energy doesn't allow such things. An amplifier almost always uses an external powerful supply of some sort and that accounts for the difference between the energy you get out and the energy you put in the extra energy is coming from the power supply to get the desired output for our demand. [5]

In general, the Peak to Average Power Ratio (PAPR) of OFDM signals is defined as the ratio between the maximum instantaneous power and average power

$$\text{PAPR} = \frac{\text{peak_power}}{\text{average_power}}$$

$$\text{PAPR}[X(t)] \text{ dB} = 10 \log \frac{\max |x(n)|^2}{E|x(n)|^2}$$

Where $\max |x(n)|^2$ represents peak output power, $E|x(n)|^2$ means average output power and $x(n)$ is the original signal [4]. The Clipping process is performed by following equation

$$x_k^c = \begin{cases} x_k & |x_k| \leq A \\ Ae^{j\phi(x_k)} & |x_k| > A \end{cases} \quad 0 \leq k \leq N - 1$$

$\varepsilon(I^{(i)}) \triangleq \min_{\mu, A} \|X^i + \mu c^{\sim(i)} - Ae^{j\varphi(i)}\|_2^2$, where A is the Amplitude and φ is the root mean squared value of unclipped signal [5].

2. Equation to calculate Bit Error Rate

$$P_{\text{QPSK}} \approx \text{erfc} \left(\sqrt{\frac{E_s}{2N_0}} \right)$$

$$P_{\text{16QAM}} \approx \frac{3}{2} \text{erfc} \left(\sqrt{\frac{E_s}{10N_0}} \right), \text{ where } E_s \text{ is the}$$

Energy and N_0 is the Noise [6]. But one of the major drawbacks of OFDM system is High Peak to Average Power Ratio which reduces the system Efficiency. Due to this problem several methods has been proposed to reduce the high peak to average power ratio of OFDM signal. Clipping and Filtering is one of them. Amplitude Clipping and Filtering is one of the easiest techniques which may be undertaken for PAPR reduction for an OFDM system. In the amplitude clipping which causes in-band and out-band signal distortion. As a result data loss will be occurred in the system. In amplitude Clipping and filtering Out-band signal distortion can be minimized by filtering but in-band distortion cannot be overcome by the technique. To solve this problem we propose a method which is called pumping based clipping. The main objective of our proposed algorithm is to control both the clipping level and convergence factor to minimize the peak power signal and target clipping level. If we perform the target clipping level consciously then in-band loss can be minimized and data loss can be recovered in the OFDM system. In this process PAPR will be reduced as well as in-band loss also can be minimized.

3. Proposed Methodology

3.1 Pumping Based Clipping: In Pumping Based Clipping the amplitude of the signal is pumped by an amplifier circuit to control both the clipping level

and convergence factor to minimize the peak power signal and target clipping level. Then generate the anti-peak signal to keep the amplitude at average level and Clip the original signal by anti-peak signal. The main purpose of this signal is to minimize the in-band and out-band loss of the clipping signal. If we perform the target clipping level consciously then in-band loss can be minimized and data loss can be recovered in the OFDM system. In this process PAPR will be reduced as well as in-band loss also can be minimized. Due to minimize of in-band loss and reduction of PAPR will develop the efficiency the OFDM system.

3.2 Steps of Proposed Algorithm

1. Pump the original signal by amplifier circuit
2. Generate anti-peak signal to keep the amplitude at average level
3. Clip original signal by anti-peak signal
4. Obtain clipped signal
5. Finally compare the PAPR of original signal to clipped signal.

3.3 Proposed Pumping Based Clipping

If the input signal is directly clipped by an anti-peak signal, then there are two types of losses called in-band and out-band losses. Hence the performance of the OFDM system is decreased. So in this model the input signal is first pumped by an pumping circuit that increase the amplitude of the original signal. Then an anti-peak signal is generated by Gaussian function. After that the pumping signal is clipped by this anti-peak signal to produce clipped signal. Then this signal is converted to digital form by using Analog to Digital converter. This signal is now fed to Inverse Fast Fourier Transform to convert frequency domain signal to time domain signal. After that Fast Fourier Transform is performed to convert time domain signal to frequency domain signal. A band pass filter is a device that passes frequencies within a certain range and rejects frequencies outside that range. At last this output is

fed to Inverse Fast Fourier Transform to get the desired output signal. In amplifier circuit the input signal is amplified by one single circuit (transistor). The output signal is the exact image of the input signal. This technology is used today mostly for preamplifiers and other small signal amplification. This type of technology is relatively simple. The amplifier circuit must be biased to make sure it works on the linear part of the transfer characteristic curve of the circuit to ensure minimal distortion. Here after amplification of the original signal it just amplifies the amplitude of the signal but not increase the power of the signal.

3.4 Proposed Pumping Based Clipping

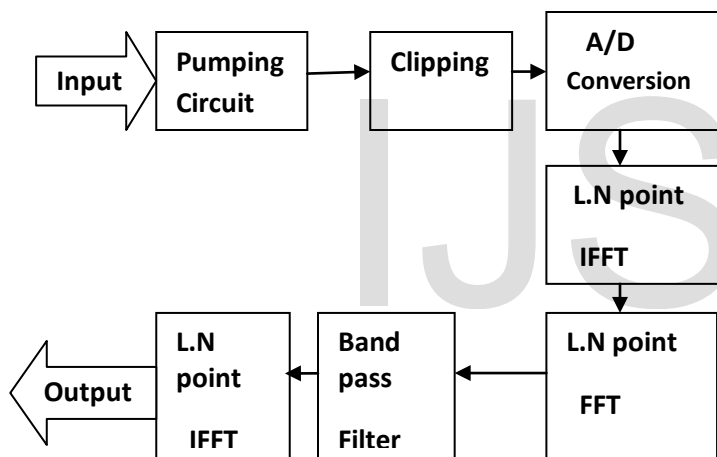

Figure: 1 Proposed Pumping Based Clipping

3.5 Pumping/Amplifier Circuit

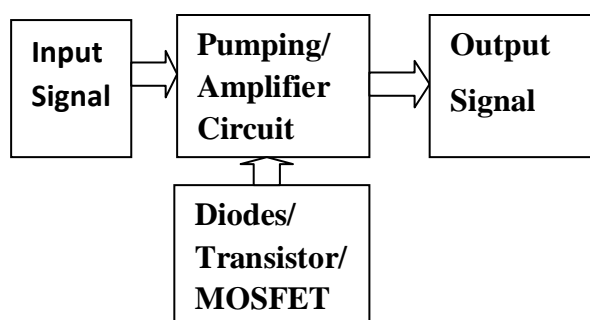

Figure: 2 Pumping/Amplifier Circuit

In amplifier circuit the input signal is amplified by one single circuit (transistor). The output signal is the exact image of the input signal. This technology is used today mostly for preamplifiers and other small signal amplification. This type of technology is relatively simple. The amplifier circuit must be biased to make sure it works on the linear part of the transfer characteristic curve of the circuit to ensure minimal distortion. Here after amplification of the original signal it just amplifies the amplitude of the signal but not increase the power of the signal.

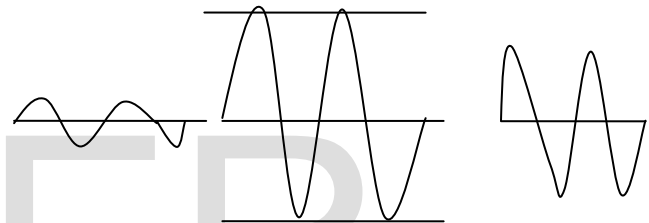

Figure: 3 Original Signal Pumping signal Clipped signal

The major drawback of OFDM system is the high PAPR; several methods have been proposed to reduce the high peak to average power ratio of OFDM signal. In Amplitude Clipping and Filtering is one of the easiest techniques to reduce PAPR of OFDM signal [8]. In the amplitude clipping which causes in-band and out-band signal distortion [9]. As a result huge amount of data loss will be occurred in the system. In amplitude Clipping and filtering Out-band signal distortion can be minimized by filtering but in-band distortion cannot be overcome by the technique. So we propose a method which is called pumping based clipping to reduce the PAPR and recover the in-band loss of OFDM system. If we use the pumping based clipping method as shown in Figure of OFDM Transmitter and Receiver, we can reduce the high PAPR as well as minimize the in-band loss of OFDM signal.

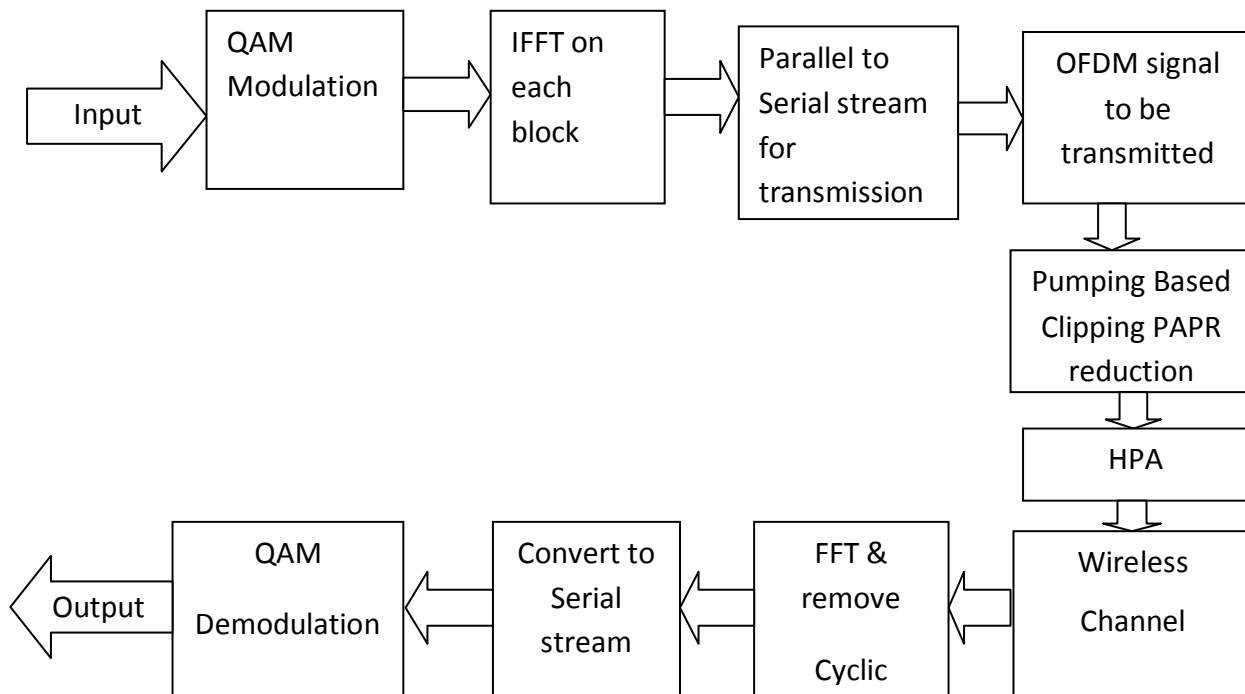

Figure: 4 OFDM Transmitters and Receiver

4. Simulation and Result

In the graph given below, the original Amplitude vs. Time signals if we observe that the highest amplitude of the signal is near about 0.5. In the peak Amplitude vs. Time signal the anti peak signal is generated by the Gaussian function. The anti peak signal is used to cut the original signal Amplitude on demand and this is shown in the clipped Amplitude vs. Time signal. After cutting the original signal by anti peak signal the clipped signal Amplitude is near about 0.3. So from our observation we can say that the overall amplitude is minimized near about 0.2 in clipped signal from the original signal.

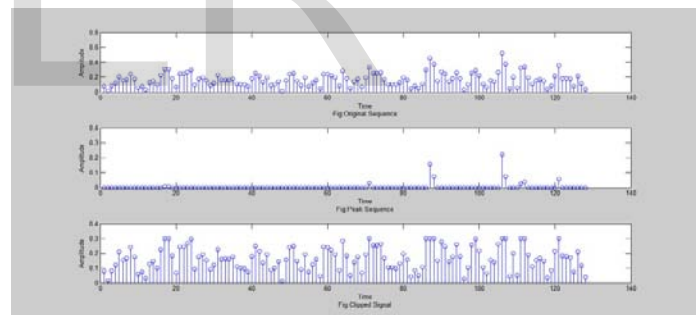

Figure: 5 Comparison among original and clipped signal

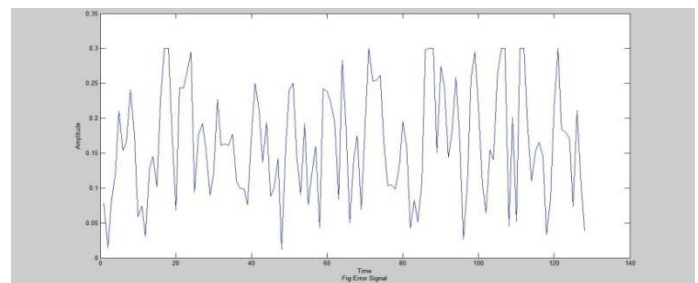

Figure: 6 Calculation of error signal from original and clipped signal

4.1 Calculation: From the equation of Peak to Average Power Ratio (PAPR):

Table: 1 Observation of PAPR and BER

Observation	PAPR of original signal in dB	PAPR of clipped signal in dB	Error
1	20.6920	5.6330	0.0070
2	15.1341	9.1400	0.000494
3	18.9141	10.1352	0.000479

By simulating in the MATLAB software, we observed error for different original signal, which is randomly generated. From our first observation the peak to average power ratio (PAPR) of the original signal is 20.6920 dB and the peak to average power ratio (PAPR) of the clipped signal is 5.6330 dB and the error rate is 0.0070 which is very small. From our second observation the peak to average power ratio (PAPR) of the original signal is 15.1341 dB and so on.

4.2 Theoretical and Simulation curve

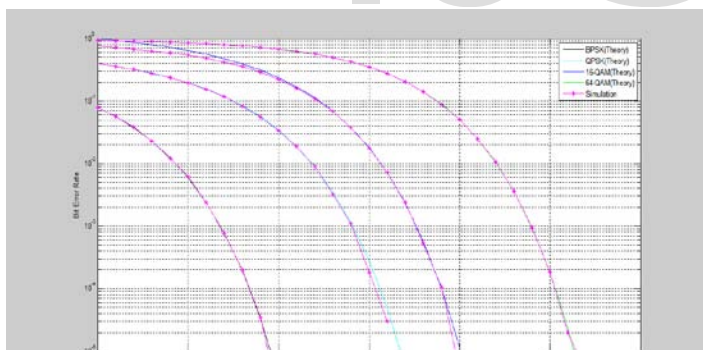

Figure: 7 Comparison of Theoretical and Simulation curve of BPSK, QPSK, 16-QAM and 64-QAM.

represented by black, magenta, blue and green color respectively. If we observe we will see BPSK technique the original black color signal is mostly overlapped by the simulated red color signal and slightly change in the last portion that is negligible. Mostly we used here QAM. For the 4-Quadrature Amplitude Modulation (4-QAM) technique the

original magenta color signal is mostly overlapped by the simulated red color signal and here is a negligible change. We similarly see for the 16-QAM and 64-QAM.

5. Conclusion:

Our proposed method pumping based PAPR reduction techniques is more efficient because PAPR is reduced; bit error rate is negligible and here in band and out band distortion is minimized largely, though an additional amplifier circuit is needed in our proposed system.

References

[1] Bosi Chen, "Spectrum Regrowth for Ofdm-Based Lte And Wimax Systems," Dissertations And Theses Dissertations And Theses Fall 1-18-2013.

[2].Md. Munjure Mowla,"Performance Analysis Of Different Higher Order Modulations For Papr Reduction," International Journal Of Advanced Science And Technology Vol.67 (2014

[3] Bosi Chen, "Spectrum Regrowth For Ofdm-Based Lte And Wimax Systems," Dissertations And Theses Dissertations And Theses Fall 1-18-2013

[4]. Suverna Sengar, Partha Pratim Bhattacharya "Performance Improvement In Ofdm System By Papr Reduction," Signal & Image Processing: An International Journal (Sipij) Vol.3, No.2, And April 2012

[5].Ritesh Baranwal, "Optimization Of Papr Using Hpa And Amplitude Clipping Reduction Technique," International Journal Of Innovative Research In Computer And Communication Engineering (An Iso 3297: 2007 Certified Organization)Vol. 2, Issue 4, April 2014

[6] [Http://En.Wikipedia.Org/Wiki/Qam](http://En.Wikipedia.Org/Wiki/Qam)

[7]. V. Vijayarangan, Dr. (Mrs) R. Sukanesh "An Overview Of Techniques For Reducing Peak To Average Power Ratio And Its Selection Criteria For Orthogonal Frequency Division Multiplexing Radio Systems," Journal Of Theoretical And Applied Information Technology

[8] Smita Jolani1, Sandeep Toshniwal "Performance Improvement Of Ofdm System Using Iterative Signal Clipping With Various Window Techniques For Papr Reduction," International Journal Of Engineering Trends And Technology (Ijett) – Volume 4 Issue 9- Sep 2013

[9] Seyran Khademi," Ofdm Peak-To-Average-Power-Ratio Reduction In Wimax Systems," Communication Systems And Information Theory Group Department Of Signals And Systems Chalmers University Of Technology Goteborg, Sweden, 2010.