

# Design and Control of Small Scale Laboratory Model of a Thyristor Controlled Series Capacitor (TCSC) to Improve System Stability

Venu Yarlagadda, Dr.B.V.Sankar Ram, Dr.K.R.M.Rao

**Abstract** - There are two types of FACTS controllers, series and shunt compensators. Series compensators reduces the transmission line reactance in order to improve Power Flow through it, while shunt compensators improves the Voltage profile. Among the FACTS devices, the TCSC controller has given the best results in terms of performance. If the oscillatory response of a power system during the transient period following a disturbance is damped and the system settles in a finite time to and flexibility. This paper investigates the effects of TCSC on voltage stability improvement and enhancement of Power Transfer Capability. Stability of the System has to be assessed based on P-V Curves for without and with Controller is the basic requirement for maintaining the voltage levels thereby the stability of the interconnected power system. Voltage variations can be stabilized and controlled by providing required reactive power.

**Index Terms:** TCSC Controller, Design of small scale TCSC Model, Variable Series Compensation, FACTS Controllers, Single Machine Two bus System, Radial system model, Voltage Stability, P-V Curves and Power System voltage Stability.

## 1 INTRODUCTION

A power system is a network of electrical components used to supply, transmit and use electric power. The interconnected power system is known as the grid and can be broadly divided into the generators that supply the power, the transmission system that carries the power from the generating centres to the load centres and the distribution system that feeds the power to nearby homes and industries.

There are many losses while transmitting the power from generation stations to load centres. The focus is more on the occurrence of different kinds of instability. Voltage stability requirements and different techniques to improve the stability like the fixed compensation and the variable compensation. FACTS controllers which are the variable compensation devices are being used for more effective results.

In this paper, series compensation of TCSC (thyristor controlled series capacitor) is used. Manual control is achieved with the observation of the error voltages and with the supply of the firing angle. Characteristic curves can be drawn with the parameters to check the stability of the system. It also deals with the significance of reactive power compensation, different sources which can produce reactive power and its different ways to provide it to the power system to limit the instability which is caused due to lack of reactive power. Relation between voltages and reactive power is also discussed.

Angle stability mainly involves the dynamics of generators and their associated control systems. Angle stability can be further categorized into transient stability and small signal or steady-state stability. Frequency stability is closely related to angle stability.

Voltage stability mainly involves the dynamic characteristics

of loads and reactive power. Voltage Collapse is perhaps the most widely recognized form of voltage instability.

Power (vars) is required to maintain the voltage to deliver active power through transmission lines. When there is not enough reactive power, the voltage sags down and it is not possible to push the power demanded by loads through the lines. Many devices contribute to systems reactive power and voltage profile. Example: Capacitors supply reactive power, inductors absorb reactive power.

Voltage stability is required for the perfect functioning of the system; compensating devices are required for the compensation purposes.

## 2 POWER SYSTEM STABILITY

### 2.1 Classification of Stability

The stability of an interconnected power system is its ability to return to its normal or stable operation after having been subjected to some form of disturbance. The tendency of synchronous machine to develop forces so as to maintain synchronism and equilibrium is called stability. The stability limit represents the maximum steady state power flow possible when the synchronous machine is operating with stability.

There are three forms of stability.

- ❖ Steady state stability
- ❖ Transient stability
- ❖ Dynamic Stability

## 2.2 Stability Improvement

Methods to improve stability are:

1. Use of double circuit lines and bundle conductors
2. Fast Acting AVR and ALFC loops
3. HVDC links
4. Fast Acting C.B's
5. FACTS Controllers
6. Load shedding

## 2.3 Voltage Stability Index - P-V curve

As the power transfer increases, the voltage at the receiving end decreases. Finally, the critical or nose point is reached. It is the point at which the system reactive power is out of use. The curve between the variation of bus voltages with loading factor is called as P-V curve or 'Nose' curve. PV curves are used to determine the loading margin of the power system. The margin between the voltage collapse point and the operating point is the available voltage stability margin.

## 3 SERIES COMPENSATION

A capacitive reactance compensator which consists of series capacitor bank shunted by a thyristor controlled reactor in order to provide a smoothly variable series capacitance reactance

### 3.1 Uncompensated Transmission Lines

Today's Interconnected Power Network is very large and has many lines, perhaps most of the lines are uncompensated leads to more reactive power losses subsequently poor voltage regulation. Some times it may leads to voltage instability and subsequently Collapse due to disturbances, sudden variations of load and contingencies. The main reason for the Voltage Collapse is due to lack of reactive power in the heavily stressed systems, Generator reactive power limits, the load characteristics, the action of the voltage control devices.

All these factors may lead to

- Limiting the Power Transfer capability of
- Un-compensated Lines
- May exceed the Line Limits subsequently
- line outages and may cause the cascading
- outages
- voltage instability and voltage collapse
- which may leads to partial blackout or Total Blockout

### 3.2 Compensated transmission lines

VCPI in When compensated transmission lines are involved, the required reactive power by the lines will be supplied or absorbed by the compensating devices which may be placed in series and/or in parallel with the transmission lines. The result of using the compensating devices is that the voltage instability does not occur. There are various types of compensating devices to be used according to the requirement like the shunt compensation and the series compensation. FACTS controllers are the compensation devices which have gained very high importance as they are variable compensation devices.

### 3.2 Objectives of Series Compensation

Shunt compensation is ineffective in controlling the actual transmitted power, which at a defined transmission voltage, is ultimately determined by the series line impedance and the angle between the voltages of line

It is always recognized that ac power transmission over long lines was primarily limited by the series reactive impedance of the line.

Series Compensators are quite affective to Improve Voltage Stability, Transient Stability. For the same level of compensation the Series Compensator size is quiet smaller than that of shunt compensator.

## 4 OPERATION OF THYRISTOR CONTROLLED SERIES CAPACITOR (TCSC)

A TCSC is a series-controlled capacitive reactance that can provide continuous control of power on the ac line over a wide range. From the system viewpoint, the principle of variable-series compensation is simply to increase the fundamental-frequency voltage across an fixed capacitor (FC) in a series compensated line through appropriate variation of the firing angle,  $\alpha$ . A simple understanding of TCSC functioning can be obtained by analyzing the behaviour of a variable inductor connected in parallel with an FC. The equivalent impedance,  $Z_{eq}$ , of this LC combination is expressed as

The impedance of the FC alone, however, is given by  $-j(1/\omega C)$ . If  $\omega C - (1/\omega L) > 0$  or, in other words,  $\omega L > (1/\omega C)$ , the reactance of the FC is less than that of the parallel-connected variable reactor and that this combination provides a variable-capacitive reactance are both implied.

If  $\omega C - (1/\omega L) = 0$ , a resonance develops that results in an infinite-capacitive impedance-an obviously unacceptable condition.

If, however,  $\omega C - (1/\omega L) < 0$ , the LC combination provides inductance above the value of the fixed inductor. This situation corresponds to the inductive- mode of the TCSC operation.

In the variable-capacitance mode of the TCSC, as the inductive reactance of the variable inductor is increased, the equivalent-capacitive reactance is gradually decreased. The minimum equivalent-capacitive reactance is obtained for extremely large inductive reactance or when the variable inductor is open-cir-

cuited, in which the value is equal to the reactance of the FC itself.

ve reactance compensator which consists of series capacitor bank shunted by a thyristor controlled reactor in order to provide a smoothly variable series capacitive reactance

#### 4.1 OBJECTIVES OF SERIES Compensation

1. It in Shunt compensation is ineffective in controlling the actual transmitted power, which at a defined transmission voltage ,is ultimately determined by the series line impedance and the angle between the voltages of line
2. It is always recognized that ac power transmission over long lines was primarily limited by the series reactive impedance of the line.
3. Series Compensators are quite affective to Improve Voltage Stability, Transient Stability, and Power Oscillation Damping and also to Mitigate SSR and Power Quality Problems.
4. For the same level of compensation the Series Compensator size is quiet small compared to the shunt compensator perhaps the degree of series compensation is limited due to SSR and FR Problems.

#### 4.2 Operation of Thyristor Controlled Series Capacitor (TCSC)

A TCSC is a series-controlled capacitive reactance that can provide continuous control of power on the ac line over a wide range. From the system viewpoint, the principle of variable-series compensation is simply to increase the fundamental-frequency voltage across an fixed capacitor (FC) in a series compensated line through appropriate variation of the firing angle,  $\alpha$ . A simple understanding of TCSC functioning can be obtained by analyzing the behaviour of a variable inductor connected in parallel with an FC. The equivalent impedance,  $Z_{eq}$ , of this LC combination is expressed as

The impedance of the FC alone, however, is given by  $-j(1/\omega C)$ . If  $\omega C - (1/\omega L) > 0$  or, in other words,  $\omega L > (1/\omega C)$ , the reactance of the FC is less than that of the parallel-connected variable reactor and that this combination provides a variable-capacitive reactance are both implied.

If  $\omega C - (1/\omega L) = 0$ , a resonance develops that results in an infinite-capacitive impedance-an obviously unacceptable condition.

If, however,  $\omega C - (1/\omega L) < 0$ , the LC combination provides inductance above the value of the fixed inductor. This situation corresponds to the inductive- mode of the TCSC operation.

In the variable-capacitance mode of the TCSC, as the inductive reactance of the variable inductor is increased, the equivalent-capacitive reactance is gradually decreased. The minimum equivalent-capacitive reactance is obtained for extremely large

inductive reactance or when the variable inductor is open-circuited, in which the value is equal to the reactance of the FC itself.

#### 4.2 Advantages of TCSC

Use of thyristor control in series capacitors potentially offers the following little-mentioned advantages:

- Rapid, continuous control of the transmission-line reactance
- Dynamic control of power flow in selected transmission lines within the network to enable optimal power-flow conditions
- Damping of the power swings from local and inter-area oscillations.
- Suppression of sub synchronous oscillations. At sub synchronous frequencies, the TCSC presents an inherently resistive-inductive reactance. The sub synchronous oscillations cannot be sustained in this situation and consequently get damped.

#### 5 IMPROVEMENT OF SYSTEM STABILITY LIMIT USING TCSC

Providing fixed-series compensation on the parallel path to augment power-transfer capability appears to be a feasible solution, but it may increase the total system losses. Therefore, it is advantageous to install a TCSC in transmission paths, which can adapt its series-compensation level to the instantaneous system requirements and provide a lower loss alternative to fixed-series compensation. The series compensation provided by the TCSC can be adjusted rapidly ensure specified magnitudes of power flow along designated transmission line. This condition is evident from the TCSC's effectively, that is, ability to change its power flow as a function of its capacitive-reactance setting:

$$P = V_1 V_2 \sin\delta / X \quad (1)$$

Where  $P$  = the power flow from bus 1 to bus 2.

$V_1, V_2$  = the voltage magnitudes of buses 1 and 2, respectively  
 $X_l$  = the line-inductive reactance,  $X_c$  = the controlled TCSC reactance combined with fixed-series capacitor Reactance.

$\delta$ =the difference in the voltage angles of buses 1,2. This change in transmitted power is further accomplished with minimal influence on the voltage of interconnecting buses, as it introduces voltage in quadrature. The freedom to locate a TCSC almost anywhere in line is a significant advantage. Power-flow control does not necessitate the high-speed operation of power flow control devices. Hence discrete control through a TSSC may also be adequate in certain situations. However, the TCSC cannot reverse the power flow in a line, unlike HVDC controllers and phase shifters.

#### 6 DESIGN CRITERION OF TCSC

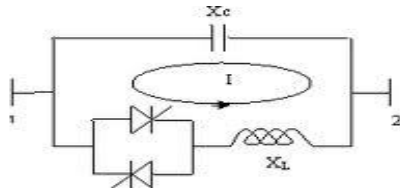

Fig.1 TCSC Schematic diagram

Consider the Line reactance of the transmission line in per unit system. For 50% compensation, the value of the capacitor in the TCSC will be 50% of the line reactance.

Now for capacitive compensation, the value of inductive reactance must be greater than capacitive reactance, that is,  $X_l > X_c$

$$X_{tcsc} = (X_l * X_c) / (X_l - X_c) \quad (2)$$

Total reactance of the line with TCSC is

$$X = X_l - X_{tcsc} \quad (3)$$

$$Q_{tcsc} = (I_c * I_c * X_c) - (I_{tcr} * I_{tcr} * X_l) \quad (4)$$

The variation of reactive power demand with load variations are obtained as

Now, if  $Q_{dmin}$  = minimum reactive power demand  
 $Q_{dmax}$  = maximum reactive power demand

$$Q_{tcsc} = Q_{dmax} - Q_{dmin} \quad (5)$$

$$Q_{ref} = Q_l = 1 \text{ p.u (corresponding to voltage value of 1 p.u)}$$

$$V = V_{ref} = 1.0 \text{ p.u}$$

$$Q_c = Q_{max} - Q_{ref}$$

$$Q_{tcr}(\alpha) = Q_{ref} - Q_{min} \quad (6)$$

$$Q_{tcsc} = Q_c - Q_{tcr}(\alpha) \quad (7)$$

Therefore

$$I_{tcr} * I_{tcr} * X_l = I_c * I_c * X_c - Q_{tcsc} \quad (8)$$

$$\text{Hence } X_l = (I_c * I_c * X_c - Q_{tcsc}) / I_{tcr} * I_{tcr} \quad (9)$$

This is the value of the inductive reactance in the TCSC circuit.

9 bus system is there as above given figure.4 it contains 9 buses, load, Generators. As per the project undertaken before, TCSC has been placed in the system to improve the voltage stability. The process undertaken for it is the GS method using the matlab simulation.

## 7 Case Study: Results

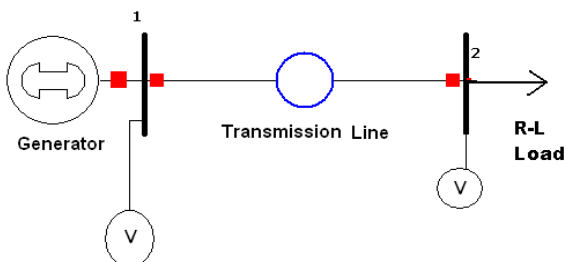

Fig.2) SMTB system without TCSC

### CASE 1:

This case is considered when the infinite bus is feeding the load through a line without any compensation.

### CASE 2:

Generator feeding the load through Transmission Line Model with TCSC.

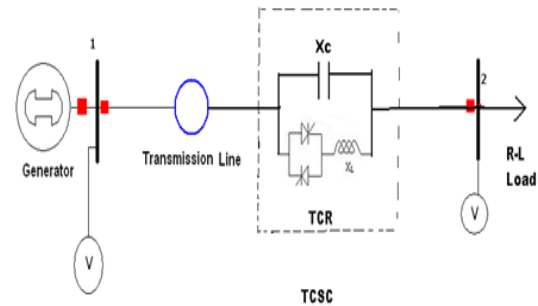

Fig.3) SMTB system without TCSC

### Laboratory Setup of SMTB Test System:

This case is considered when the generator is feeding

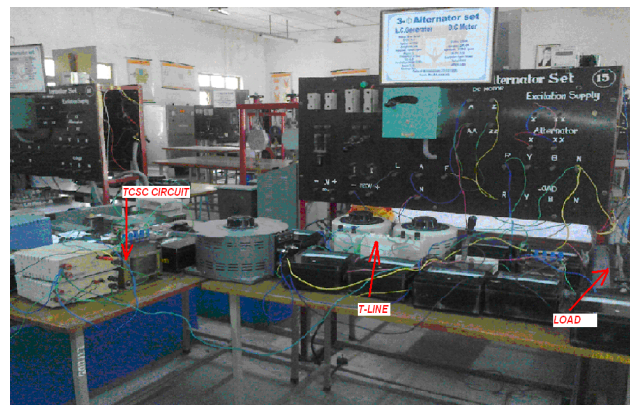

Fig.4) Lab setup of SMTB system with TCSC

the load through a line. To estimate the stability of the system, the P-V curves have been drawn for the SMTB test system without and with TCSC.

### PV Curves With and Without TCSC

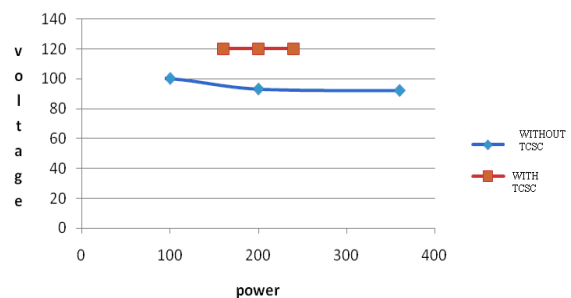

Fig.5) P-V Curves without and with TCSC



The SMTB test system with a source feeding the RL load through a transmission line model and tested with and without TCSC. PV curves have been drawn for both the cases. The system stability has been assessed with PV curves. The results shows that improvement in the stability margin. Series capacitive compensation is thus used to reduce the series reactive impedance to minimize receiving end voltage variation and the possibility of voltage collapse. It is also observed that the compensation by using this technique i.e TCSC is faster when compared to other compensating techniques such as mechanical switching and synchronous condensers.

## 8 Conclusions

The results shows that there is improvement in the stability margin when TCSC is connected in the test system. Series capacitive compensation is thus used to reduce the series reactive impedance to minimize receiving end voltage variation and the possibility of voltage collapse. It is also observed that the compensation by using this technique i.e TCSC is more effective than other compensating techniques such as mechanical switching and synchronous condensers.

## References

1. N.G. Hingorani and L. Gyugyi, Understanding FACTS, IEEE Press, New York, USA, 1999
2. R.M. Mathur and R.K. Varma, Thyristor-Based FACTS Controllers for Electrical Transmission Systems, IEEE Press and Wiley Interscience, New York, USA, Feb. 2002.
3. D M Tagare, Reactive Power Management, McGraw-Hill Publication, India,1982.
4. IEEE Power Engg. Society/CIGRE, "FACTS Overview", Publication 95 TP 108, IEEE Press, New York, 1995.
5. P. Kundur, Power System Stability and Control, McGraw-Hill, Inc., New York, 1994.
6. IEEE Power Engineering Society, "FACTS Applications", Publication 96 TP 116-0, IEEE Press, New York, 1996
7. W.A.Lyon, Transient Analysis of Alternating-Current Machinery, Chapter 2, John Wiley, New York, 1954.
8. N.Noroozian, m.ghandari, "improving power system dynamics by series connected facts devices", iee trans. power delivery, vol. 12, n<sup>o</sup> 4, pp. 1635-1641, oct. 1997.
8. D.Irwin, Basic Engineering Circuit Analysis. 4th Ed., Mac-milan , New York 1993.
9. Jack R. Smith , Programming the PIC *microcontroller*. , McGraw-Hill Publication, India, 2005.
10. A.Mohamed, G.B.Jasmon, S.Yusoff "A Static Voltage Collapse Indicator using Line Stability Factors" Journal of Industrial Technology, Vol.7, N1, pp. 73-85, 1989
11. P.Kessel, H.Glavitsch "Estimating the Voltage Stability of a Power System" IEEE, Transactions on Power Delivery, Vol.PWRD-1, N3, July 1986

## Acknowledgements

We are immensely thankful to Management and Principal of VNR VJIET for providing R&D lab and other facilities to carryout this work.

## AUTHORS BIOGRAPHY



**Mr. Venu Yarlalagadda**, is Obtained his B.Tech and M.Tech Degrees from JNT University, Hyderabad, Andhra Pradesh and also perusing PhD From same University. Currently working as Associate Professor in VNR VJIET, AP, India. Current areas of Interests are FACTS, Power Systems, Intelligent Systems and Electrical Machines. Published Two Research papers in International Journals, Presented Two International and One National Conference papers.  
E-Mail : [venuyar@gmail.com](mailto:venuyar@gmail.com), [venu\\_y@vnrvijet.in](mailto:venu_y@vnrvijet.in)



**Dr. B.V. Sankar Ram**, Currently working as a Professor of EEE Dept, JNTU, Hyderabad, He obtained his PhD from JNTU and M.Tech and B.Tech from O.U, Hyderabad. Published Nine Research papers in International Journals, Presented 19 International and National Conference papers, Currently Guiding Ten PhD's. Current areas of Interests are Power System Reliability, Power Systems, Deregulation and FACTS.



**Dr. K.R.M Rao**, Currently working as Professor and Head MJCET, Hyderabad. He obtained his PhD from Poland and guided two PhD's and Currently Guiding two PhD's. Current Areas of Interests are Power System Reliability, Electrical Drives, Power Electronics and FACTS.